

AC Servomotor/Servo Drives

Replace Guide

From G Series with MECHATROLINK-II Communications
to G5 Series with MECHATROLINK-II Communications

R88M-K[], R88D-KN[]-ML2

R88M-G[], R88D-GN[]-ML2



Replace
Guide

NOTE

All rights reserved. No part of this publication may be reproduced, stored in a retrieval system, or transmitted, in any form, or by any means, mechanical, photocopying, recording, or otherwise, without the prior written permission of OMRON.

No patent liability is assumed with respect to the use of the information contained herein. Moreover, because OMRON is constantly striving to improve its high-quality products, the information contained in this manual is subject to change without notice. Every precaution has been taken in the preparation of this manual. Nevertheless, OMRON assumes no responsibility for errors or omissions. Neither is any liability assumed for damages resulting from the use of the information contained in this publication.

Introduction

This Guide does not contain safety information and other details that are required for actual use. Thoroughly read and understand the manuals for all of the devices that are used in this Guide to ensure that the system is used safely. Review the entire contents of these materials, including all safety precautions, precautions for safe use, and precautions for correct use.

Intended Audience

This Guide is intended for the following personnel.

- Personnel in charge of introducing FA systems
- Personnel in charge of designing FA systems

The personnel must also have the following knowledge.

- Knowledge of electrical systems (an electrical engineer or the equivalent)
- Knowledge of AC Servomotors/Drives

Applicable Products

This Guide covers the following products.

- G-series AC Servomotors/Servo Drivers with Built-in MECHATROLINK-II Communications
- G5-series AC Servomotors/Servo Drivers with Built-in MECHATROLINK-II Communications

Terms and Conditions Agreement

Warranties

(a) Exclusive Warranty. Omron's exclusive warranty is that the Products will be free from defects in materials and workmanship for a period of twelve months from the date of sale by Omron (or such other period expressed in writing by Omron). Omron disclaims all other warranties, express or implied.

(b) Limitations. OMRON MAKES NO WARRANTY OR REPRESENTATION, EXPRESS OR IMPLIED, ABOUT NON-INFRINGEMENT, MERCHANTABILITY OR FITNESS FOR A PARTICULAR PURPOSE OF THE PRODUCTS. BUYER ACKNOWLEDGES THAT IT ALONE HAS DETERMINED THAT THE PRODUCTS WILL SUITABLY MEET THE REQUIREMENTS OF THEIR INTENDED USE.

Omron further disclaims all warranties and responsibility of any type for claims or expenses based on infringement by the Products or otherwise of any intellectual property right. (c) Buyer Remedy.

Omron's sole obligation hereunder shall be, at Omron's election, to (i) replace (in the form originally shipped with Buyer responsible for labor charges for removal or replacement thereof) the non-complying Product, (ii) repair the non-complying Product, or (iii) repay or credit Buyer an amount equal to the purchase price of the non-complying Product; provided that in no event shall Omron be responsible for warranty, repair, indemnity or any other claims or expenses regarding the Products unless Omron's analysis confirms that the Products were properly handled, stored, installed and maintained and not subject to contamination, abuse, misuse or inappropriate modification. Return of any Products by Buyer must be approved in writing by Omron before shipment. Omron Companies shall not be liable for the suitability or unsuitability or the results from the use of Products in combination with any electrical or electronic components, circuits, system assemblies or any other materials or substances or environments. Any advice, recommendations or information given orally or in writing, are not to be construed as an amendment or addition to the above warranty.

See <http://www.omron.com/global/> or contact your Omron representative for published information.

Limitation on Liability; Etc

OMRON COMPANIES SHALL NOT BE LIABLE FOR SPECIAL, INDIRECT, INCIDENTAL, OR CONSEQUENTIAL DAMAGES, LOSS OF PROFITS OR PRODUCTION OR COMMERCIAL LOSS IN ANY WAY CONNECTED WITH THE PRODUCTS, WHETHER SUCH CLAIM IS BASED IN CONTRACT, WARRANTY, NEGLIGENCE OR STRICT LIABILITY.

Further, in no event shall liability of Omron Companies exceed the individual price of the Product on which liability is asserted.

Suitability of Use

Omron Companies shall not be responsible for conformity with any standards, codes or regulations which apply to the combination of the Product in the Buyer's application or use of the Product. At Buyer's request, Omron will provide applicable third party certification documents identifying ratings and limitations of use which apply to the Product. This information by itself is not sufficient for a complete determination of the suitability of the Product in combination with the end product, machine, system, or other application or use. Buyer shall be solely responsible for determining appropriateness of the particular Product with respect to Buyer's application, product or system. Buyer shall take application responsibility in all cases.

NEVER USE THE PRODUCT FOR AN APPLICATION INVOLVING SERIOUS RISK TO LIFE OR PROPERTY WITHOUT ENSURING THAT THE SYSTEM AS A WHOLE HAS BEEN DESIGNED TO ADDRESS THE RISKS, AND THAT THE OMRON PRODUCT(S) IS PROPERLY RATED AND INSTALLED FOR THE INTENDED USE WITHIN THE OVERALL EQUIPMENT OR SYSTEM.

Programmable Products

Omron Companies shall not be responsible for the user's programming of a programmable Product, or any consequence thereof.

Performance Data

Data presented in Omron Company websites, catalogs and other materials is provided as a guide for the user in determining suitability and does not constitute a warranty. It may represent the result of Omron's test conditions, and the user must correlate it to actual application requirements. Actual performance is subject to the Omron's Warranty and Limitations of Liability

Change in Specifications

Product specifications and accessories may be changed at any time based on improvements and other reasons. It is our practice to change part numbers when published ratings or features are changed, or when significant construction changes are made. However, some specifications of the Product may be changed without any notice. When in doubt, special part numbers may be assigned to fix or establish key specifications for your application. Please consult with your Omron's representative at any time to confirm actual specifications of purchased Product.

Errors and Omissions

Information presented by Omron Companies has been checked and is believed to be accurate; however, no responsibility is assumed for clerical, typographical or proofreading errors or omissions.

Precautions

- When building a system, check the specifications for all devices and equipment that will make up the system and make sure that the OMRON products are used well within their rated specifications and performances. Safety measures, such as safety circuits, must be implemented in order to minimize the risks in the event of a malfunction.
- Thoroughly read and understand the manuals for all devices and equipment that will make up the system to ensure that the system is used safely. Review the entire contents of these manuals, including all safety precautions, precautions for safe use, and precautions for correct use.
- Confirm all regulations, standards, and restrictions that the system must adhere to.
- Check the user program for proper execution before you use it for actual operation.

Trademarks

- EtherCAT® is registered trademark and patented technology, licensed by Beckhoff Automation GmbH, Germany.
- Microsoft product screen shot(s) reprinted with permission from Microsoft Corporation.
- Other company names and product names in this Guide are the trademarks or registered trademarks of their respective companies.

Revision History

A manual revision code appears as a suffix to the catalog number on the front and back covers of the manual.

Cat. No.	I878-E1-02
-----------------	-------------------

↑
Revision code

Revision code	Date	Revised content
01	April 2022	Original production
02	January 2024	Correction of error

CONTENTS

Introduction.....	3
Intended Audience	3
Applicable Products	3
Terms and Conditions Agreement	4
Precautions	6
Trademarks	6
Revision History	7
1. Outline	9
2. Precautions for Replacement	10
3. Replacement List.....	11
3.1. Servomotors with Rated Rotation Speed of 3,000 r/min	11
3.2. Flat Servomotors with Rated Rotation Speed of 3,000 r/min	11
3.3. Servomotors with Rated Rotation Speed of 2,000 r/min and 1,500 r/min.....	11
3.4. Servomotors with Rated Rotation Speed of 1,000 r/min	12
4. Comparison of Servomotor Dimensions	13
4.1. Servomotors with Rated Rotation Speed of 3,000 r/min (Main Circuit Power Supply Voltage: 100 V or 200 V)	13
4.2. Servomotors with Rated Rotation Speed of 2,000 r/min (Main Circuit Power Supply Voltage: 200 V)	18
4.3. Servomotors with Rated Rotation Speed of 1,500 r/min (Main Circuit Power Supply Voltage: 200 V)	19
4.4. Servomotors with Rated Rotation Speed of 1,000 r/min (Main Circuit Power Supply Voltage: 200 V)	20
5. Comparison of Servo Drive Dimensions	22
6. Layout and Specifications of Connectors and Terminal Blocks of Servo Drive	24
6.1. Layout and Specifications of Connectors and Terminal Blocks of Main Circuit Wiring and Motor Wiring	24
6.2. Layout and Specifications of Connectors of Control Circuit	28
7. Gain Adjustment Methods	31
7.1. Gain Adjustment Method (Auto Tuning)	31
7.2. Using Gain Adjustment Values for G-ML2 Series as Those for G5-ML2 Series	36
8. Connecting with Host Controllers	37
9. Detailed Comparison of Parameters	38
9.1. Function Selection Parameters	38
9.2. Parameters Related to Gain	40
9.3. Parameters Related to Position Control	45
9.4. Parameters Related to Speed and Torque Control	47
9.5. Parameters Related to Sequence	48
9.6. 16-bit Positioning Parameters: Parameter Nos. 100 to 13F	51
9.7. 32-bit Positioning Parameters: Parameter Nos. 200 to 21F	53
Appendix. Cables Connecting G5-ML2-series Servo Drives and Servomotors	54

1. Outline

Thank you for adopting the Omron Servomotors and Servo Drives.

This manual describes the comparative information for replacing the conventional G-series AC Servomotors/Servo Drivers with Built-in MECHATROLINK-II Communications, R88M-G□ and R88D-GN□-ML2, (hereinafter called the G-ML2 series or G-ML2) with the G5-series AC Servomotors/Servo Drivers with Built-in MECHATROLINK-II Communications, R88M-K□ and R88D-KN□-ML2, (hereinafter called the G5-ML2 series or G5-ML2).

To check the details that are not described in this manual, refer to the User's Manual for the Servomotors and Servo Drives concerned.

No.	Manual No.	Manual name
1.	I566	R88M-G□, R88D-GN□-ML2 AC Servomotors/Servo Drivers with Built-in MECHATROLINK-II Communications G series User's Manual
2.	I572	R88M-K□, R88D-KN□-ML2 AC Servomotors/Servo Drives with Built-in MECHATROLINK-II Communications G5 series User's Manual

2. Precautions for Replacement

The following table shows the precautions for replacing the G-ML2 series with the G5-ML2 series.

Read the comparisons of both series shown in this manual and the User's Manual of both series, before considering replacement.

No.	Classification	Item	G-ML2 series	G5-ML2 series	Remarks	
1.	Specifications and performance	Speed response frequency	1 kHz	2 kHz	Both the specifications and performance are improved in the G5-ML2 series.	
2.		Encoder resolution	<ul style="list-style-type: none"> Incremental encoder Phases A and B: 2,500 pulses/rotation (Multiple of 4: 10,000 pulses/rotation) Absolute (absolute value) encoder 17 bits Phases A and B: 32,768 pulses/rotation (Multiple of 4: 131,072 pulses/rotation) 	<ul style="list-style-type: none"> Incremental encoder Phases A and B: 262,144 pulses/rotation (Multiple of 4: 1,048,576 pulses/rotation) Absolute (absolute value) encoder 17 bits Phases A and B: 32,768 pulses/rotation (Multiple of 4: 131,072 pulses/rotation) 		
3.		Output signal	There are four output signals: <ul style="list-style-type: none"> Alarm Output (fixed) General-purpose Output 1 (set by Pn112) General-purpose Output 2 (set by Pn113) General-purpose Output 3 (set by Pn114) 	There are three output signals: <ul style="list-style-type: none"> Alarm output (fixed) General-purpose output 1 (set by Pn410) General-purpose output 2 (set by Pn411) 		The G5-ML2 series has less output signals by one. Set appropriate functions to the general-purpose outputs to make adjustments.
4.		Parameter Unit	Present	Absent		For the G5-ML2 series, parameters are set from CX-Drive (computer tool).
5.		Servomotor dimensions	Standard type	Example) 100 W motor: □40×92		Example) 100 W motor: □40×92
6.	Flat type		Example) 100 W motor: □60×60.5	Example) 100 W motor: □40×92	The G5-ML2 series has no flat Servomotors, so the dimensions are significantly different.	
7.	Comparison of dimensions between R88M-G1K030T□ and R88M-K1K030T□		<ul style="list-style-type: none"> Without brake: □90×175 With brake: □90×200 	<ul style="list-style-type: none"> Without brake: □100×141 With brake: □100×168 	The motor frame is enlarged from □90 to □100.	
8.	Comparison of dimensions between R88M-G4K020T□ and R88M-K4K020T□		<ul style="list-style-type: none"> Without brake: □150×242 With brake: □150×267 	<ul style="list-style-type: none"> Without brake: □176×177 With brake: □176×206 	The motor frame is enlarged from □150 to □176.	
9.	R88M-G7K515T□ R88M-G4K510T□ R88M-G6K010T□		Present	Absent * The G5-ML2 series does not have the corresponding motors.	Consider replacing with the G5 series with built-in EtherCAT communications.	
10.	Drip-proof structure		IP65	IP67	It is improved in the G5-ML2 series.	
11.	Servo Drive dimensions	Drive body	Example) 100 W drive: 150×40×132	Example) 100 W drive: 150×40×132	Same in dimensions.	
12.		R88D-GT75H	Present * Front mounting only	Absent * The G5-ML2 series does not have the corresponding drives.	Consider replacing with the G5 series with built-in EtherCAT communications.	
13.	Function	STO function	Absent	Present	All the functions are covered because of upward compatibility. However, parameter Nos. are different, so refer to 9. <i>Detailed Comparison of Parameters.</i>	
14.		RS-232/485 function	Present	Absent (Substituted with USB function)		
15.		Fully-closed control	Absent	Present		

3. Replacement List

3.1. Servomotors with Rated Rotation Speed of 3,000 r/min

Main circuit power supply voltage	G-ML2 series			G5-ML2 series			Remarks
	Motor capacity	Motor model R88M-	Drive model R88D-	Motor capacity	Motor model R88M-	Drive model R88D-	
Single-phase 100 V	50 W	G05030H/T□	GNA5L-ML2	50 W	K05030H/T□	KNA5L-ML2	Compatible with 200-V Servomotors.
	100 W	G10030L/S□	GN01L-ML2	100 W	K10030L/S□	KN01L-ML2	
	200 W	G20030L/S□	GN02L-ML2	200 W	K20030L/S□	KN02L-ML2	
	400 W	G40030L/S□	GN04L-ML2	400 W	K40030L/S□	KN04L-ML2	
Single-phase 200 V	50 W	G05030H/T□	GN01H-ML2	50 W	K05030H/T□	KN01H-ML2	
	100 W	G10030H/T□	GN01H-ML2	100 W	K10030H/T□	KN01H-ML2	
	200 W	G20030H/T□	GN02H-ML2	200 W	K20030H/T□	KN02H-ML2	
	400 W	G40030H/T□	GN04H-ML2	400 W	K40030H/T□	KN04H-ML2	
	750 W	G75030H/T□	GN08H-ML2	750 W	K75030H/T□	KN08H-ML2	
	1 kW	G1K030T□	GN15H-ML2	1 kW	K1K030T□	KN15H-ML2	
	1.5 kW	G1K530T□	GN15H-ML2	1.5 kW	K1K530T□	KN15H-ML2	
3-phase 200 V	750 W	G75030H/T□	GN08H-ML2	750 W	K75030H/T□	KN08H-ML2	The motor flange dimension is changed from □90 to □100.
	1 kW	G1K030T□	GN15H-ML2	1 kW	K1K030T□	KN15H-ML2	
	1.5 kW	G1K530T□	GN15H-ML2	1.5 kW	K1K530T□	KN15H-ML2	
	2 kW	G2K030T□	GN20H-ML2	2 kW	K2K030T□	KN20H-ML2	
	3 kW	G3K030T□	GN30H-ML2	3 kW	K3K030T□	KN30H-ML2	
	4 kW	G4K030T□	GN50H-ML2	4 kW	K4K030T□	KN50H-ML2	
	5 kW	G5K030T□	GN50H-ML2	5 kW	K5K030T□	KN50H-ML2	

3.2. Flat Servomotors with Rated Rotation Speed of 3,000 r/min

Main circuit power supply voltage	G-ML2 series			G5-ML2 series			Remarks
	Motor capacity	Motor model R88M-	Drive model R88D-	Motor capacity	Motor model R88M-	Drive model R88D-	
Single-phase 100 V	100 W	GP10030L/S□	GN01L-ML2	100 W	K10030L/S□	KN01L-ML2	The G5-ML2 series has no flat type of Servomotors, so the external dimensions are significantly different.
	200 W	GP20030L/S□	GN02L-ML2	200 W	K20030L/S□	KN02L-ML2	
	400 W	GP40030L/S□	GN04L-ML2	400 W	K40030L/S□	KN04L-ML2	
Single-phase 200 V	100 W	GP10030H/T□	GN01H-ML2	100 W	K10030H/T□	KN01H-ML2	
	200 W	GP20030H/T□	GN02H-ML2	200 W	K20030H/T□	KN02H-ML2	
	400 W	GP40030H/T□	GN04H-ML2	400 W	K40030H/T□	KN04H-ML2	

3.3. Servomotors with Rated Rotation Speed of 2,000 r/min and 1,500 r/min

Main circuit power supply voltage	G-ML2 series			G5-ML2 series			Remarks
	Motor capacity	Motor model R88M-	Drive model R88D-	Motor capacity	Motor model R88M-	Drive model R88D-	
Single-phase 200 V	1 kW	G1K020T□	GN10H-ML2	1 kW	K1K020T□	KN10H-ML2	
	1.5 kW	G1K520T□	GN15H-ML2	1.5 kW	K1K520T□	KN15H-ML2	
3-phase 200 V	1 kW	G1K020T□	GN10H-ML2	1 kW	K1K020T□	KN10H-ML2	
	1.5 kW	G1K520T□	GN15H-ML2	1.5 kW	K1K520T□	KN15H-ML2	
	2 kW	G2K020T□	GN20H-ML2	2 kW	K2K020T□	KN20H-ML2	
	3 kW	G3K020T□	GN30H-ML2	3 kW	K3K020T□	KN30H-ML2	
	4 kW	G4K020T□	GN50H-ML2	4 kW	K4K020T□	KN50H-ML2	The motor flange dimension is changed from □150 to □176.
	5 kW	G5K020T□	GN50H-ML2	5 kW	K5K020T□	KN50H-ML2	
	7.5 kW	G7K515T□	GN75H-ML2	7.5 kW	(K7K515T□)	(KN75H-ECT)	G5-ML2 has no counterpart.*

* The G5 series with built-in MECHATROLINK-II communications has no model to be replaced with, so consider replacing with the G5 series with built-in EtherCAT communications.

3.4. Servomotors with Rated Rotation Speed of 1,000 r/min

Main circuit power supply voltage	G-ML2 series			G5-ML2 series			Remarks
	Motor capacity	Motor model R88M-	Drive model R88D-	Motor capacity	Motor model R88M-	Drive model R88D-	
Single-phase 200 V	900 W	G90010T□	GN15H-ML2	900 W	K90010T□	KN15H-ML2	
3-phase 200 V	900 W	G90010T□	GN15H-ML2	900 W	K90010T□	KN15H-ML2	
	2 kW	G2K010T□	GN30H-ML2	2 kW	K2K010T□	KN30H-ML2	
	3 kW	G3K010T□	GN50H-ML2	3 kW	K3K010T□	KN50H-ML2	
	4.5 kW	G4K510T□	GN50H-ML2	4.5 kW	(K4K510T□)	(KN50H-ECT)	G5-ML2 has no counterpart.*
	6 kW	G6K010T□	GN75H-ML2	6 kW	(K6K010T□)	(KN75H-ECT)	G5-ML2 has no counterpart.*

* The G5 series with built-in MECHATROLINK-II communications has no model to be replaced with, so consider replacing with the G5 series with built-in EtherCAT communications.

4. Comparison of Servomotor Dimensions

Since the G-ML2 series and the G5-ML2 series are different in Servomotor dimensions, check the following comparison of dimensions in designing.

- Leaders and dimensions (symbols) on outline drawings and dimensional drawings are shown in **red** for ease of recognition.
- For dimensions (numbers) in tables, the dimensions becoming larger and smaller when the G-ML2 series is replaced with the G5-ML2 series are respectively shown in **red** and **blue**.

4.1. Servomotors with Rated Rotation Speed of 3,000 r/min (Main Circuit Power Supply Voltage: 100 V or 200 V)

■ 50 W or 100 W motor (100 V or 200 V)

- G without 50 W or 100 W brake

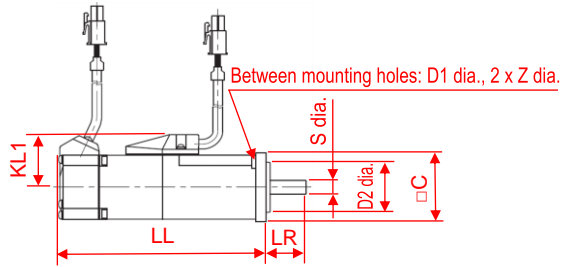

- G with 50 W or 100 W brake

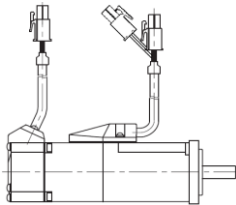

- G5 without 50 W or 100 W brake

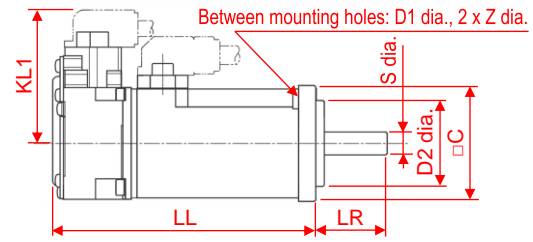

- G5 with 50 W or 100 W brake

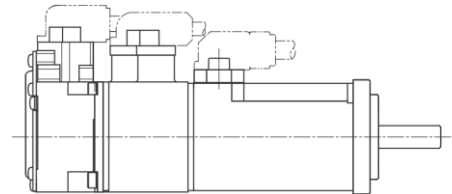

Motor capacity	Specifications	Series	Motor model R88M-	Dimension [mm]							Remarks	
				LL	LR	S	D1	D2	C	Z		KL1
50 W	Without brake	G-ML2 series	G05030□	72	25	8	46	30	40	4.3	32	Connectors are located differently. • For G-ML2, connectors are located on the lead cable ends. • For G5-ML2, connectors are located on the Servomotor body.
		G5-ML2 series	K05030□	72	25	8	46	30	40	4.3	46.6	
	With brake	G-ML2 series	G05030□-B□	102	25	8	46	30	40	4.3	32	
		G5-ML2 series	K05030□-B□	102	25	8	46	30	40	4.3	46.6	
100 W	Without brake	G-ML2 series	G10030□	92	25	8	46	30	40	4.3	32	
		G5-ML2 series	K10030□	92	25	8	46	30	40	4.3	46.6	
	With brake	G-ML2 series	G10030□-B□	122	25	8	46	30	40	4.3	32	
		G5-ML2 series	K10030□-B□	122	25	8	46	30	40	4.3	46.6	

■ 200 W or 400 W motor (100 V or 200 V)

● G without 200 W or 400 W brake

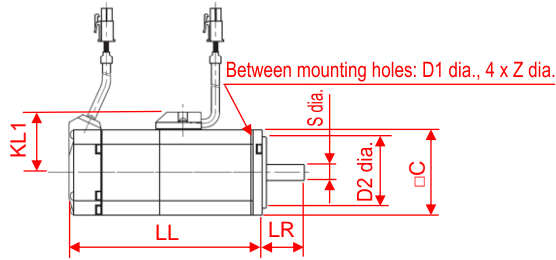

● G with 200 W or 400 W brake

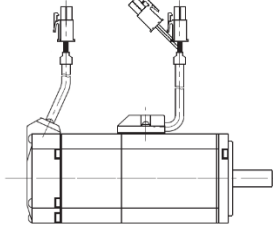

● G5 without 200 W or 400 W brake

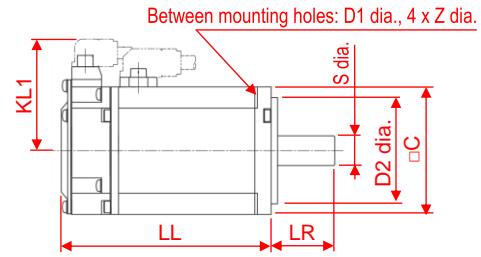

● G5 with 200 W or 400 W brake

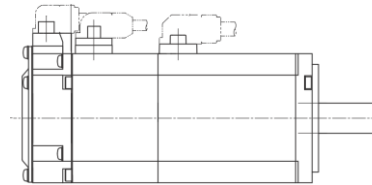

Motor capacity	Specifications	Series	Motor model R88M-	Dimension [mm]								Remarks
				LL	LR	S	D1	D2	C	Z	KL1	
200 W	Without brake	G-ML2 series	G20030□	79.5	30	11	70	50	60	4.5	43	Connectors are located differently. ● For G-ML2, connectors are located on the lead cable ends. ● For G5-ML2, connectors are located on the Servomotor body.
		G5-ML2 series	K20030□	79.5	30	11	70	50	60	4.5	52.5	
	With brake	G-ML2 series	G20030□-B□	116	30	11	70	50	60	4.5	43	
		G5-ML2 series	K20030□-B□	116	30	11	70	50	60	4.5	52.5	
400 W	Without brake	G-ML2 series	G40030□	99	30	14	70	50	60	4.5	43	Connectors are located differently. ● For G-ML2, connectors are located on the lead cable ends. ● For G5-ML2, connectors are located on the Servomotor body.
		G5-ML2 series	K40030□	99	30	14	70	50	60	4.5	52.5	
	With brake	G-ML2 series	G40030□-B□	135.5	30	14	70	50	60	4.5	43	
		G5-ML2 series	K40030□-B□	135.5	30	14	70	50	60	4.5	52.5	

■ 750 W motor (200 V)

● G without 750 W brake

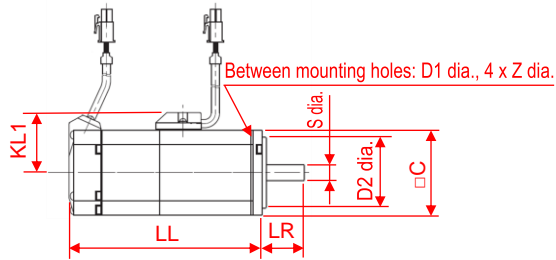

● G with 750 W brake

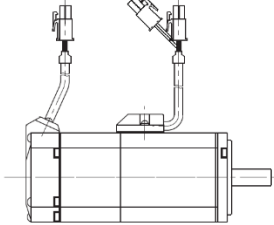

● G5 without 750 W brake

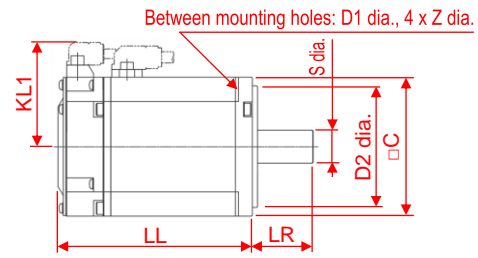

● G5 with 750 W brake

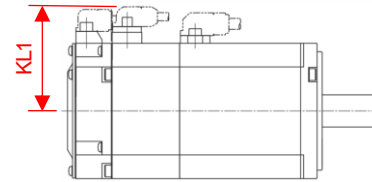

Motor capacity	Specifications	Series	Motor model R88M-	Dimension [mm]								Remarks
				LL	LR	S	D1	D2	C	Z	KL1	
750 W	Without brake	G-ML2 series	G75030□	112.2	35	19	90	70	80	6	53	Connectors are located differently. ● For G-ML2, connectors are located on the lead cable ends. ● For G5-ML2, connectors are located on the Servomotor body.
		G5-ML2 series	K75030□	112.2	35	19	90	70	80	6	60	
	With brake	G-ML2 series	G75030□-B□	149.2	35	19	90	70	80	6	53	
		G5-ML2 series	K75030□-B□	148.2	35	19	90	70	80	6	61.6	

■ 1 kW, 1.5 kW, 2 kW, 3 kW, 4 kW, or 5 kW motor (200 V)

• G of 1 kW, 1.5 kW, 2 kW, 3 kW, 4 kW, or 5 kW

• G5 of 1 kW, 1.5 kW, 2 kW, 3 kW, 4 kW, or 5 kW

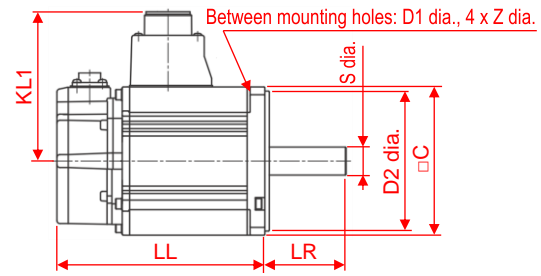
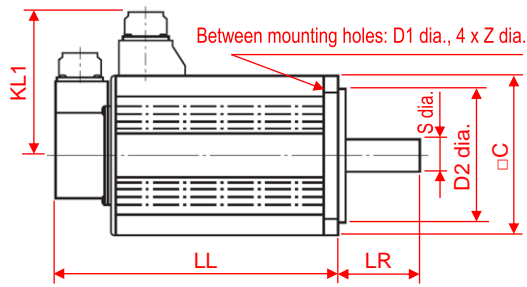

Motor capacity	Specifications	Series	Motor model R88M-	Dimension [mm]								Remarks
				LL	LR	S	D1	D2	C	Z	KL1	
1 kW	Without brake	G-ML2 series	G1K030T□	175	55	19	100	80	90	6.6	98	Connector directions are the same.
		G5-ML2 series	K1K030T□	141	55	19	115	95	100	9	101	
	With brake	G-ML2 series	G1K030T-B□	200	55	19	100	80	90	6.6	98	
		G5-ML2 series	K1K030T-B□	168	55	19	115	95	100	9	101	
1.5 kW	Without brake	G-ML2 series	G1K530T□	180	55	19	115	95	100	9	103	
		G5-ML2 series	K1K530T□	159.5	55	19	115	95	100	9	101	
	With brake	G-ML2 series	G1K530T-B□	205	55	19	115	95	100	9	103	
		G5-ML2 series	K1K530T-B□	186.5	55	19	115	95	100	9	101	
2 kW	Without brake	G-ML2 series	G2K030T□	205	55	19	115	95	100	9	103	
		G5-ML2 series	K2K030T□	178.5	55	19	115	95	100	9	101	
	With brake	G-ML2 series	G2K030T-B□	230	55	19	115	95	100	9	103	
		G5-ML2 series	K2K030T-B□	205.5	55	19	115	95	100	9	101	
3 kW	Without brake	G-ML2 series	G3K030T□	217	55	22	145	110	120	9	111	
		G5-ML2 series	K3K030T□	190	55	22	145	110	120	9	113	
	With brake	G-ML2 series	G3K030T-B□	242	55	22	145	110	120	9	111	
		G5-ML2 series	K3K030T-B□	215	55	22	145	110	120	9	113	
4 kW	Without brake	G-ML2 series	G4K030T□	240	65	24	145	110	130	9	118	
		G5-ML2 series	K4K030T□	208	65	24	145	110	130	9	118	
	With brake	G-ML2 series	G4K030T-B□	265	65	24	145	110	130	9	118	
		G5-ML2 series	K4K030T-B□	236	65	24	145	110	130	9	118	
5 kW	Without brake	G-ML2 series	G5K030T□	280	65	24	145	110	130	9	118	
		G5-ML2 series	K5K030T□	243	65	24	145	110	130	9	118	
	With brake	G-ML2 series	G5K030T-B□	305	65	24	145	110	130	9	118	
		G5-ML2 series	K5K030T-B□	271	65	24	145	110	130	9	118	

4.2. Servomotors with Rated Rotation Speed of 2,000 r/min (Main Circuit Power Supply Voltage: 200 V)

■ 1 kW, 1.5 kW, 2 kW, 3 kW, 4 kW, or 5 kW motor (200 V)

● G of 1 kW, 1.5 kW, 2 kW, 3 kW, 4 kW, or 5 kW

● G5 of 1 kW, 1.5 kW, 2 kW, 3 kW, 4 kW, or 5 kW

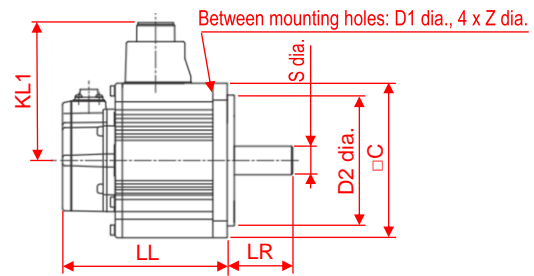
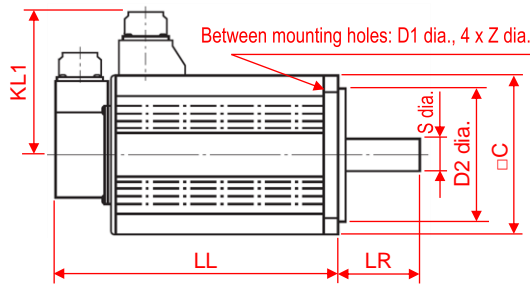

Motor capacity	Specifications	Series	Motor model R88M-	Dimension [mm]							Remarks	
				LL	LR	S	D1	D2	C	Z		KL1
1 kW	Without brake	G-ML2 series	G1K020T□	150	55	22	145	110	130	9	118	Connector directions are the same.
		G5-ML2 series	K1K020T□	138	55	22	145	110	130	9	116	
	With brake	G-ML2 series	G1K020T-B□	175	55	22	145	110	130	9	118	
		G5-ML2 series	K1K020T-B□	166	55	22	145	110	130	9	116	
1.5 kW	Without brake	G-ML2 series	G1K520T□	175	55	22	145	110	130	9	118	
		G5-ML2 series	K1K520T□	155.5	55	22	145	110	130	9	116	
	With brake	G-ML2 series	G1K520T-B□	200	55	22	145	110	130	9	118	
		G5-ML2 series	K1K520T-B□	183.5	55	22	145	110	130	9	116	
2 kW	Without brake	G-ML2 series	G2K020T□	200	55	22	145	110	130	9	118	
		G5-ML2 series	K2K020T□	173	55	22	145	110	130	9	116	
	With brake	G-ML2 series	G2K020T-B□	225	55	22	145	110	130	9	118	
		G5-ML2 series	K2K020T-B□	201	55	22	145	110	130	9	116	
3 kW	Without brake	G-ML2 series	G3K020T□	250	65	24	145	110	130	9	118	
		G5-ML2 series	K3K020T□	208	65	24	145	110	130	9	118	
	With brake	G-ML2 series	G3K020T-B□	275	65	24	145	110	130	9	118	
		G5-ML2 series	K3K020T-B□	236	65	24	145	110	130	9	118	
4 kW	Without brake	G-ML2 series	G4K020T□	242	65	28	165	130	150	11	128	
		G5-ML2 series	K4K020T□	177	70	35	200	114.3	176	13.5	140	
	With brake	G-ML2 series	G4K020T-B□	267	65	28	165	130	150	11	128	
		G5-ML2 series	K4K020T-B□	206	70	35	200	114.3	176	13.5	140	
5 kW	Without brake	G-ML2 series	G5K020T□	225	70	35	200	114.3	176	13.5	143	
		G5-ML2 series	K5K020T□	196	70	35	200	114.3	176	13.5	140	
	With brake	G-ML2 series	G5K020T-B□	250	70	35	200	114.3	176	13.5	143	
		G5-ML2 series	K5K020T-B□	225	70	35	200	114.3	176	13.5	140	

4.3. Servomotors with Rated Rotation Speed of 1,500 r/min (Main Circuit Power Supply Voltage: 200 V)

■ 7.5 kW motor (200 V)

* The G5 series is a Servomotor for the type with built-in EtherCAT communications.

• G of 7.5 kW

• G5 of 7.5 kW

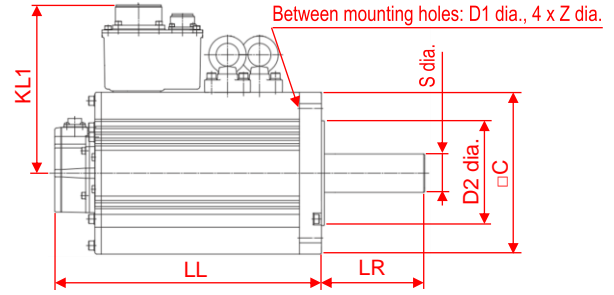
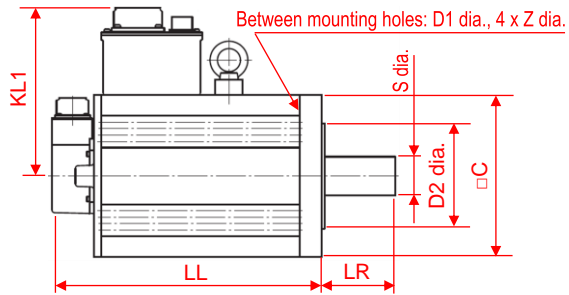

Motor capacity	Specifications	Series	Motor model R88M-	Dimension [mm]								Remarks
				LL	LR	S	D1	D2	C	Z	KL1	
7.5 kW	Without brake	G-ML2 series	G7K515T□	340.5	113	42	200	114.3	176	13.5	183	Connector directions are the same.
		(G5-ECT series)	(K7K515T□)	312	113	42	200	114.3	176	13.5	184	
	With brake	G-ML2 series	G7K515T-B□	380.5	113	42	200	114.3	176	13.5	183	
		(G5-ECT series)	(K7K515T-B□)	337	113	42	200	114.3	176	13.5	184	

4.4. Servomotors with Rated Rotation Speed of 1,000 r/min (Main Circuit Power Supply Voltage: 200 V)

■ 900 W, 2 kW, or 3 kW motor (200 V)

- G of 900 W, 2 kW, or 3 kW

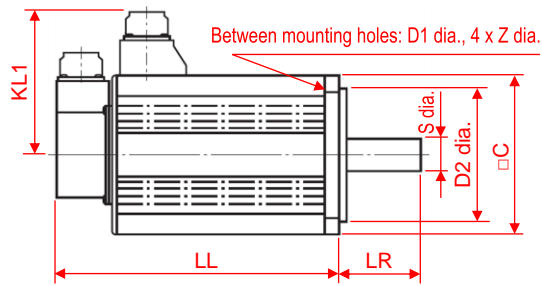

- G5 of 900 W, 2 kW, or 3 kW

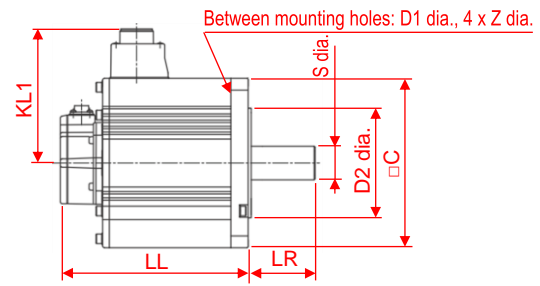

Motor capacity	Specifications	Series	Motor model R88M-	Dimension [mm]								Remarks
				LL	LR	S	D1	D2	C	Z	KL1	
900 W	Without brake	G-ML2 series	G90010T□	175	70	22	145	110	130	9	118	Connector directions are the same.
		G5-ML2 series	K90010T□	155.5	70	22	145	110	130	9	116	
	With brake	G-ML2 series	G90010T-B□	200	70	22	145	110	130	9	118	
		G5-ML2 series	K90010T-B□	183.5	70	22	145	110	130	9	116	
2 kW	Without brake	G-ML2 series	G2K010T□	182	80	35	200	114.3	176	13.5	143	
		G5-ML2 series	K2K010T□	163.5	80	35	200	114.3	176	13.5	140	
	With brake	G-ML2 series	G2K010T-B□	207	80	35	200	114.3	176	13.5	143	
		G5-ML2 series	K2K010T-B□	192.5	80	35	200	114.3	176	13.5	140	
3 kW	Without brake	G-ML2 series	G3K010T□	222	80	35	200	114.3	176	13.5	143	
		G5-ML2 series	K3K010T□	209.5	80	35	200	114.3	176	13.5	140	
	With brake	G-ML2 series	G3K010T-B□	271	80	35	200	114.3	176	13.5	143	
		G5-ML2 series	K3K010T-B□	238.5	80	35	200	114.3	176	13.5	140	

■ **4.5 kW motor (200 V)**

* The G5 series is a Servomotor for the type with built-in EtherCAT communications.

● G of 4.5 kW

● G5 of 4.5 kW

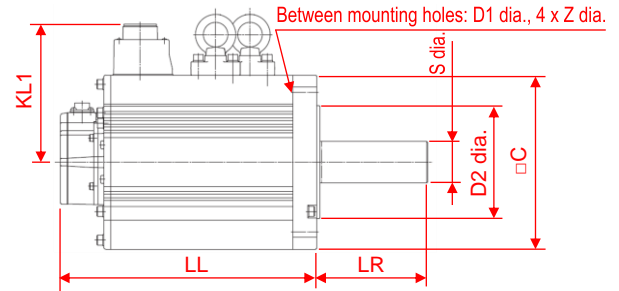
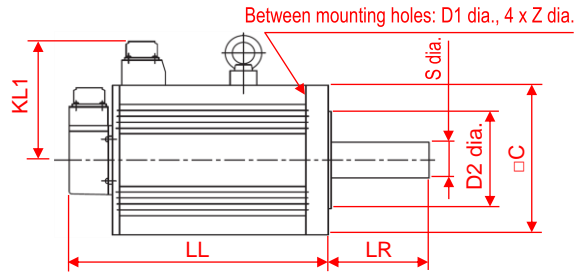

Motor capacity	Specifications	Series	Motor model R88M-	Dimension [mm]								Remarks
				LL	LR	S	D1	D2	C	Z	KL1	
4.5 kW	Without brake	G-ML2 series	G4K510T□	300.5	113	42	200	114.3	176	13.5	143	Connector directions are the same.
		(G5-ECT series)	(K4K510T□)	266	113	42	200	114.3	176	13.5	140	
	With brake	G-ML2 series	G4K510T-B□	337.5	113	42	200	114.3	176	13.5	143	
		(G5-ECT series)	(K4K510T-B□)	291	113	42	200	114.3	176	13.5	140	

■ **6 kW motor (200 V)**

* The G5 series is a Servomotor for the type with built-in EtherCAT communications.

● G of 6 kW

● G5 of 6 kW

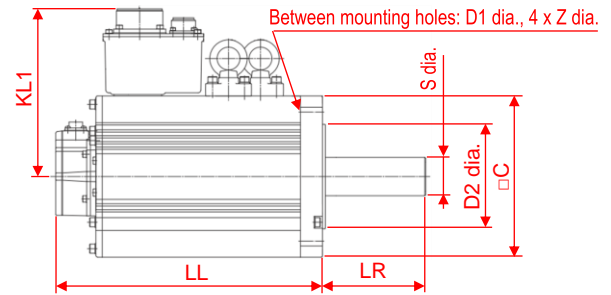
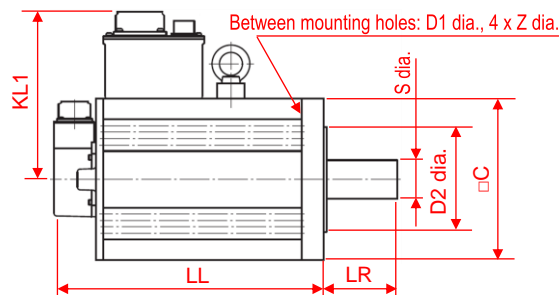

Motor capacity	Specifications	Series	Motor model R88M-	Dimension [mm]								Remarks
				LL	LR	S	D1	D2	C	Z	KL1	
6 kW	Without brake	G-ML2 series	G6K010T□	340.5	113	42	200	114.3	176	13.5	183	Connector directions are the same.
		(G5-ECT series)	(K6K010T□)	312	113	42	200	114.3	176	13.5	184	
	With brake	G-ML2 series	G6K010T-B□	380.5	113	42	200	114.3	176	13.5	183	
		(G5-ECT series)	(K6K010T-B□)	337	113	42	200	114.3	176	13.5	184	

5. Comparison of Servo Drive Dimensions

Since the G-ML2 series and the G5-ML2 series are different in drive dimensions, check the following comparison of dimensions in designing.

- Leaders and dimensions (symbols) on outline drawings and dimensional drawings are shown in **red** for ease of recognition.
- For dimensions (numbers) in tables, the dimensions becoming larger and smaller when the G-ML2 series is replaced with the G5-ML2 series are respectively shown in **red** and **blue**.

■ Reference outline drawings of drives

• G Drive R88D-GN01H-ML2

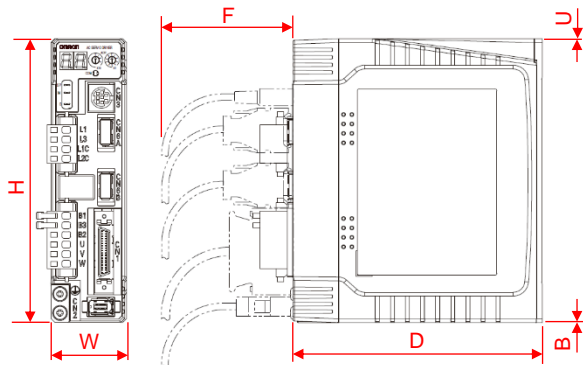

• G5 Drive R88D-KN01H-ML2

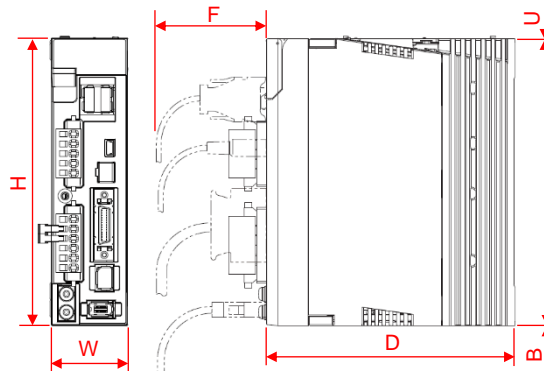

• G Drive R88D-GN20H-ML2

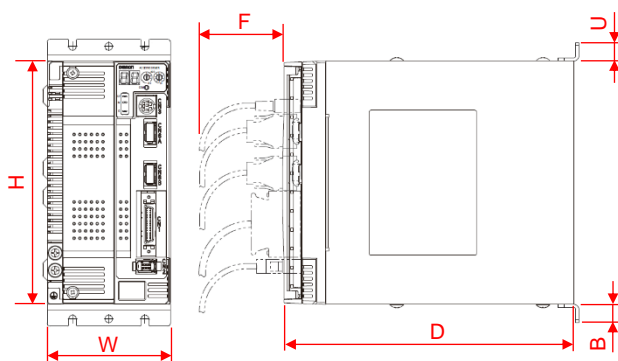

• G5 Drive R88D- KN20H-ML2

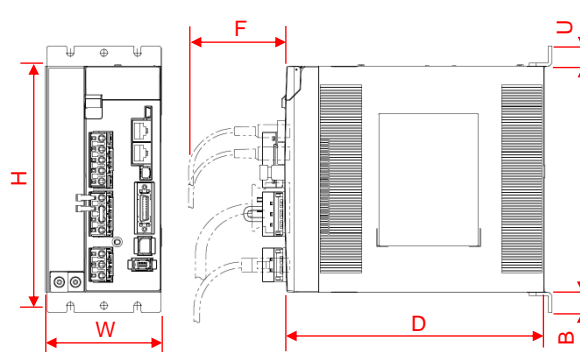

• G Drive R88D-GN75H-ML2

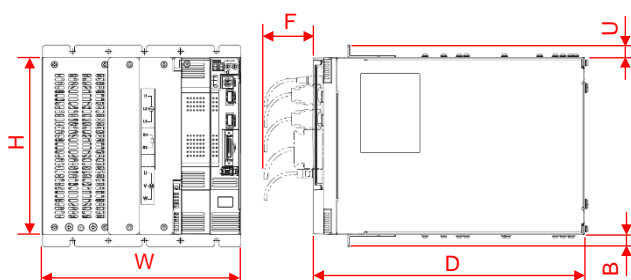

• (G5-ECT Drive R88D-KN75H-ECT)

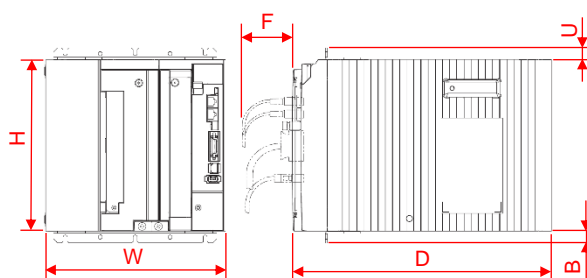

■ Main circuit power supply voltage 200 V drive dimensions

Motor capacity	Series	Drive model R88D-	Dimension [mm]						Remarks	
			H	W	D	F	U	B		
100 W or 200 W	G-ML2 series	GN01H-ML2/GN02H-ML2	150	40	132	70	0	0		
	G5-ML2 series	KN01H-ML2/KN02H-ML2	150	40	132	70	0	0		
400 W	G-ML2 series	GN04H-ML2	150	55	132	70	0	0		
	G5-ML2 series	KN04H-ML2	150	55	132	70	0	0		
750 W	G-ML2 series	GN08H-ML2	150	65	172	70	0	0		
	G5-ML2 series	KN08H-ML2	150	65	172	70	0	0		
1 kW or 1.5 kW	G-ML2 series	GN10H-ML2/GN15H-ML2	150	85	172	70	0	0		
	G5-ML2 series	KN10H-ML2/KN15H-ML2	150	86	172	70	0	0		
2 kW	G-ML2 series	GN20H-ML2	168	85	200	70	15	15		
	G5-ML2 series	KN20H-ML2	168	86	195	70	15	15		
3 kW or 5 kW	G-ML2 series	GN30H-ML2/GN50H-ML2	220	130	200	70	15	15		
	G5-ML2 series	KN30H-ML2/KN50H-ML2	220	130	214	70	15	15		
7.5 kW	G-ML2 series	GN75H-ML2	220	248	339.3	70	15	15		<ul style="list-style-type: none"> • For G-ML2, front mounting is only allowed. • For (G5-ECT), wall mounting and front mounting are both allowed.
	(G5-ECT series)	(KN75H-ECT)*	220	233	334	70	15	15		

* Dimensions of the Servo Drive with built-in EtherCAT communications are written for the G5 series.

■ Main circuit power supply voltage 100 V drive dimensions

Motor capacity	Series	Drive model R88D-	Dimension [mm]						Remarks
			H	W	D	F	U	B	
50 W to 100 W	G-ML2 series	GNA5L-ML2/GN01L-ML2	150	40	132	70	0	0	
	G5-ML2 series	KNA5L-ML2/KN01L-ML2	150	40	132	70	0	0	
200 W	G-ML2 series	GN02L-ML2	150	55	132	70	0	0	
	G5-ML2 series	KN02L-ML2	150	55	132	70	0	0	
400 W	G-ML2 series	GN04L-ML2	150	65	172	70	0	0	
	G5-ML2 series	KN04L-ML2	150	65	172	70	0	0	

6. Layout and Specifications of Connectors and Terminal Blocks of Servo Drive

The G5-ML2 series has inherited the layout and specifications of connectors and terminal blocks of the G-ML2 series, so you can change wiring without great difficulty. The below shows the layout and specifications of the connectors and terminal blocks of each drive model. Read the descriptions, and then consider replacement design.

6.1. Layout and Specifications of Connectors and Terminal Blocks of Main Circuit Wiring and Motor Wiring

- 50 W to 200 W drives (100 V) or 100 W to 400 W drives (200 V)

G-ML2 series:

R88D-GNA5L-ML2/GN01L-ML2/GN02L-ML2/GN01H-ML2/GN02H-ML2/GN04H-ML2

G5-ML2 series:

R88D-KNA5L-ML2/KN01L-ML2/KN02L-ML2/KN01H-ML2/KN02H-ML2/KN04H-ML2

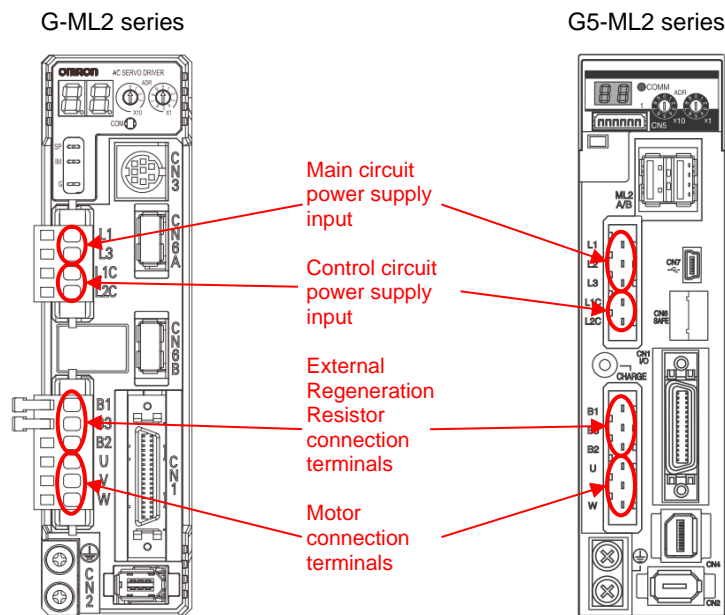

In both the G-ML2 and the G5-ML2 series, input single-phase 100 V and 200 V to the L1 terminal and the L3 terminal.

G-ML2 series				G5-ML2 series			
Terminal	Symbol	Name	Outline specifications	Terminal	Symbol	Name	Outline specifications
CNA	L1	Main circuit power supply input	Single-phase 100 to 115 VAC Single-phase 200 to 240 VAC	CNA	L1	Main circuit power supply input	Single-phase 100 to 120 VAC Single-phase 200 to 240 VAC 3-phase 200 to 240 VAC
	L3				L3		
	L1C	Control circuit power supply input	Single-phase 100 to 115 VAC Single-phase 200 to 240 VAC		L1C	Control circuit power supply input	Single-phase 100 to 120 VAC Single-phase 200 to 240 VAC
	L2C				L2C		
CNB	B1	External Regeneration Resistor connection terminals	Internal Regeneration Resistor: B2–B3 short-circuited External Regeneration Resistor: B1–B2 connected	CNB	B1	External Regeneration Resistor connection terminals	Internal Regeneration Resistor: B2–B3 short-circuited External Regeneration Resistor: B1–B2 connected
	B3				B3		
	B2				B2		
	U	Motor connection terminals	Motor output of phase U, phase V, and phase W		U	Motor connection terminals	Motor output of phase U, phase V, and phase W
	V				V		
W	W						

- 400 W drive (100 V) or 750 W to 1.5 kW drives (200 V)
G-ML2 series: R88D-GN04L-ML2/GN08H-ML2/GN10H-ML2/GN15H-ML2
G5-ML2 series: R88D-KN04L-ML2/KN08H-ML2/KN10H-ML2/KN15H-ML2

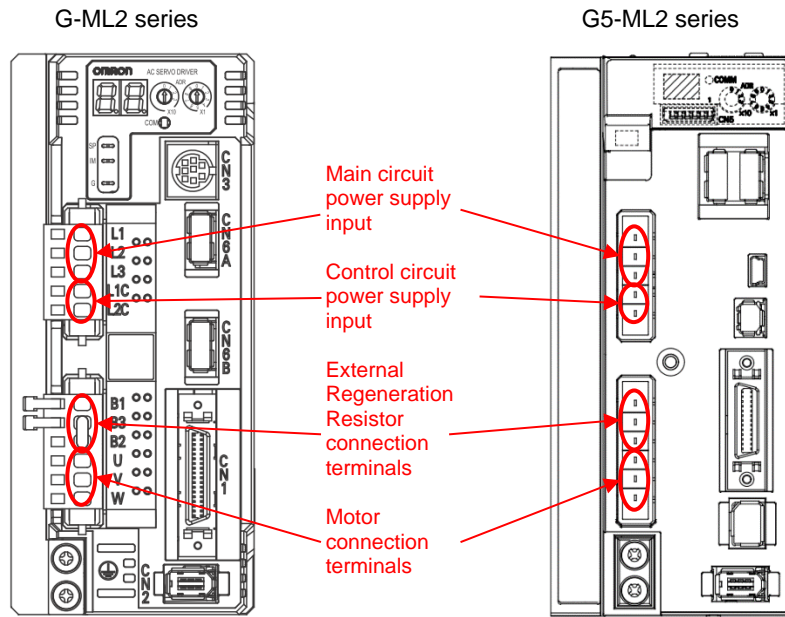

In both the G-ML2 and the G5-ML2 series, input single-phase 100 V and 200 V to the L1 terminal and the L3 terminal.

G-ML2 series				G5-ML2 series			
Terminal	Symbol	Name	Outline specifications	Terminal	Symbol	Name	Outline specifications
CNA	L1	Main circuit power supply input	Single-phase 100 to 115 VAC	CNA	L1	Main circuit power supply input	Single-phase 100 to 120 VAC
	L2		Single-phase 200 to 240 VAC		L2		Single-phase 200 to 240 VAC
	L3		3-phase 200 to 240 VAC		L3		3-phase 200 to 240 VAC
	L1C	Control circuit power supply input	Single-phase 100 to 115 VAC		L1C	Control circuit power supply input	Single-phase 100 to 120 VAC
L2C	Single-phase 200 to 240 VAC		L2C	Single-phase 200 to 240 VAC			
CNB	B1	External Regeneration Resistor connection terminals	Internal Regeneration Resistor: B2–B3 short-circuited External Regeneration Resistor: B1–B2 connected	CNB	B1	External Regeneration Resistor connection terminals	Internal Regeneration Resistor: B2–B3 short-circuited External Regeneration Resistor: B1–B2 connected
	B3				B3		
	B2				B2		
	U	Motor connection terminals	Motor output of phase U, phase V, and phase W		U	Motor connection terminals	Motor output of phase U, phase V, and phase W
	V				V		
W	W						

■ 2 kW drive (200 V)
 G-ML2 series: R88D-GN20H-ML2
 G5-ML2 series: R88D-KN20H-ML2

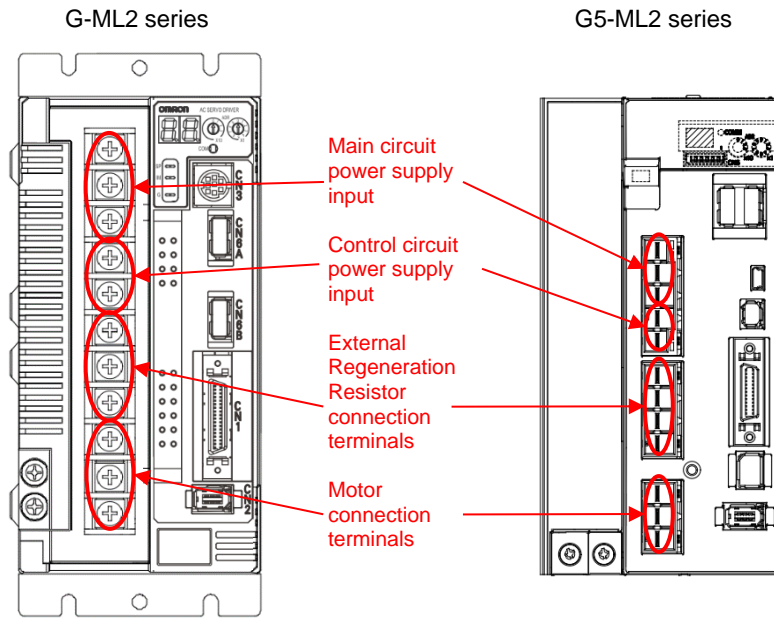

G-ML2 series				G5-ML2 series					
Terminal	Symbol	Name	Outline specifications	Terminal	Symbol	Name	Outline specifications		
TB	L1	Main circuit power supply input	3-phase 200 to 230 VAC	CNA	L1	Main circuit power supply input	3-phase 200 to 230 VAC		
	L2				L2			Control circuit power supply input	Single-phase 200 to 230 VAC
	L3				L3				
	L1C	Control circuit power supply input	Single-phase 200 to 230 VAC		L1C	Control circuit power supply input	Single-phase 200 to 230 VAC		
	L2C				L2C				
	B1	External Regeneration Resistor connection terminals	Internal Regeneration Resistor: B2–B3 short-circuited External Regeneration Resistor: B1–B2 connected	CND	B1	External Regeneration Resistor connection terminals	Internal Regeneration Resistor: B2–B3 short-circuited External Regeneration Resistor: B1–B2 connected		
	B3				B3				
B2	B2								
U	Motor connection terminals	Motor output of phase U, phase V, and phase W	NC	-	Do not connect.				
V			CNB	U	Motor connection terminals	Motor output of phase U, phase V, and phase W			
W				V					
				W					

■ 3 kW to 5 kW drives (200 V)
G-ML2 series: R88D-GN30H-ML2/GN50H-ML2
G5-ML2 series: R88D-KN30H-ML2/KN50H-ML2

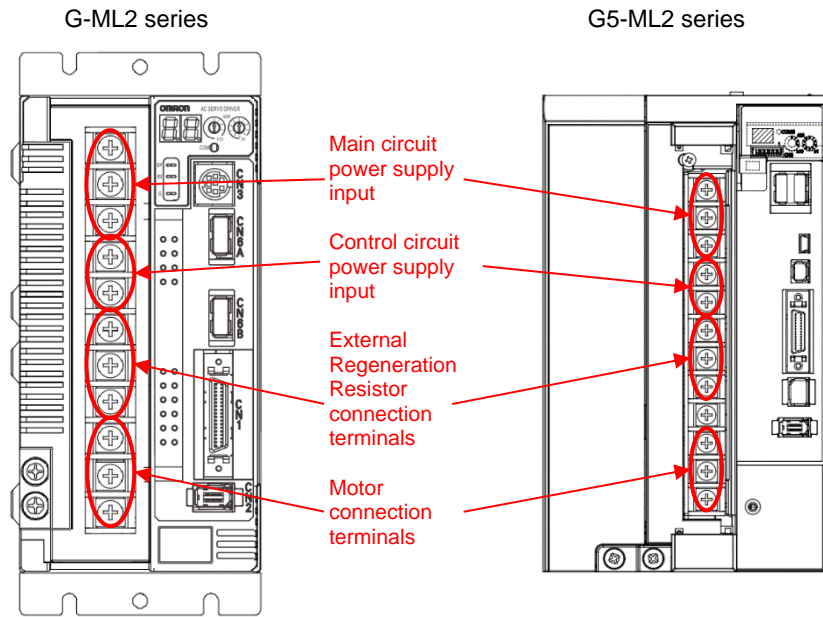

G-ML2 series				G5-ML2 series			
Terminal	Symbol	Name	Outline specifications	Terminal	Symbol	Name	Outline specifications
TB	L1	Main circuit power supply input	3-phase 200 to 230 VAC	TB	L1	Main circuit power supply input	3-phase 200 to 230 VAC
	L2				L2		
	L3				L3		
	L1C	Control circuit power supply input	Single-phase 200 to 230 VAC		L1C	Control circuit power supply input	Single-phase 200 to 230 VAC
	L2C				L2C		
	B1	External Regeneration Resistor connection terminals	Internal Regeneration Resistor: B2–B3 short-circuited External Regeneration Resistor: B1–B2 connected		B1	External Regeneration Resistor connection terminals	Internal Regeneration Resistor: B2–B3 short-circuited External Regeneration Resistor: B1–B2 connected
	B3				B3		
B2	B2						
U	Motor connection terminals	Motor output of phase U, phase V, and phase W	NC	-	Do not connect.		
V			U	Motor connection terminals	Motor output of phase U, phase V, and phase W		
W			V				
				W			

6.2. Layout and Specifications of Connectors of Control Circuit

Layout of connectors of control circuit

The control circuit connectors are arranged on the drive front.

The G5-ML2 series does not support the RS-232 communications and Parameter Unit functions of the G-ML2 series. For the G5-ML2 series, parameters can be set from CX-Drive (computer tool) via USB communications.

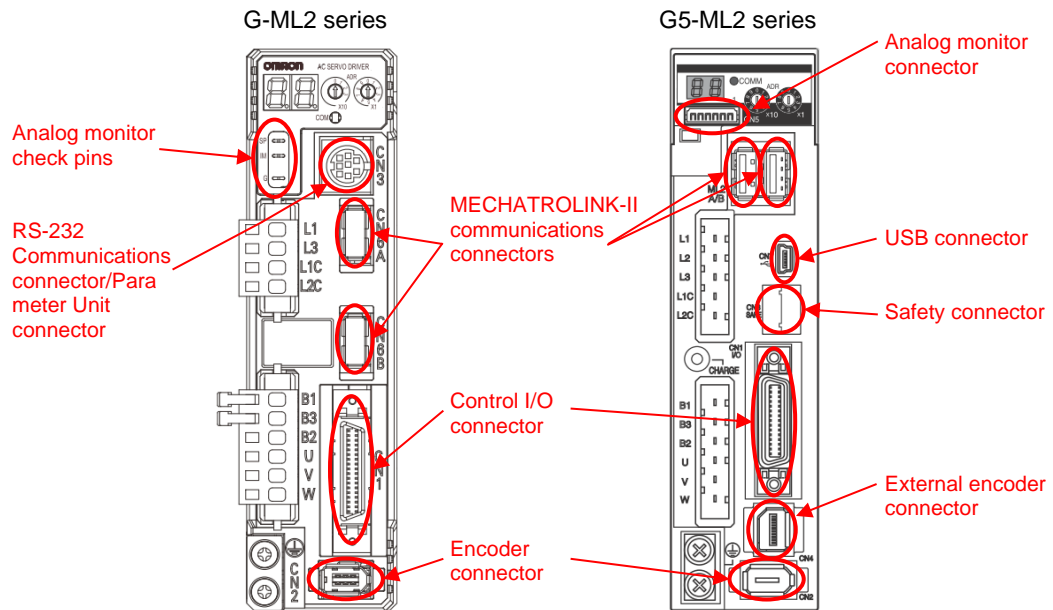

Control I/O connector

Control input

Although the G-ML2 series has 12 control inputs, the function of each control input is fixed.

The eight control inputs of the G5-ML2 series are general-purpose inputs, and the functions can be changed by using **Input Signal Selection 1** (Pn400) to **8** (Pn407).

According to the control inputs that are used actually in the G-ML2 series, change the input functions of the G5 series.

G-ML2 series				G5-ML2 series			
Terminal	No.	Symbol	Name	Terminal	No.	Symbol	Name
CN1	1	+24VIN	12 to 24-VDC Power Supply Input	CN1	6	+24VIN	12 to 24-VDC Power Supply Input
	2	STOP	Emergency Stop Input*1		5	IN1 (STOP)	General-purpose Input 1 (Emergency Stop Input)*5
	3	EXT3	External Latch Signal 3		7	IN2 (POT)	General-purpose Input 2 (Forward Drive Prohibition Input)*5
	4	EXT2	External Latch Signal 2		8	IN3 (NOT)	General-purpose Input 3 (Reverse Drive Prohibition Input)*5
	5	EXT1	External Latch Signal 1		9	IN4 (DEC)	General-purpose Input 4 (Origin Proximity Input)*5
	6	IN1	External General-purpose Input 1		10	IN5(EXT3)	General-purpose Input 5 (External Latch Input 3)*5
	7	PCL	Forward Torque Limit Input*2		11	IN6(EXT2)	General-purpose Input 6 (External Latch Input 2)*5
	8	NCL	Reverse Torque Limit Input*2		12	IN7(EXT1)	General-purpose Input 7 (External Latch Input 1)*5
	19	POT	Forward Drive Prohibit Input*3		13	IN8 (MON0)	General-purpose Input 8 (Monitor Input 0)*5
	20	NOT	Reverse Drive Prohibit Input*3		-	-	No corresponding input.
	21	DEC	Origin Proximity Input*4		-	-	
	22	IN0	External General-purpose Input 0		-	-	
	23	IN2	External General-purpose Input 2		-	-	
	34	BAT	Backup Battery Input		14	BAT	Backup battery input
33	BATCOM	15		BATGND			

*1. You can enable or disable the function by using **Emergency Stop Input Setting** (Pn041). The default setting is 1: Enabled (STOP: CN1-2 pin).

*2. You can enable or disable the function by using **Torque Limit Selection** (Pn003). The default setting is 1: Disabled (Forward/Reverse limit value Pn05E).

*3. You can enable or disable the function by using **Drive Prohibit Input Selection** (Pn004). The default setting is 0: Enabled.

Moreover, you can change PCL to CN1-20 pin and NCL to CN1-19 pin, by using **Input Signal Selection** (Pn044).

*4. You can change the input logic by using **Origin Proximity Input Logic Setting** (Pn042). The default setting is 1: NO contact (Positive logic).

*5. For the functions of general-purpose inputs 1 to 8, input functions and logics for them can be changed by using **Input Signal Selection 1** (Pn400) to **8** (Pn407).

The setting in parentheses shows the default setting.

[Electrical specifications]

- In both the G-ML2 and the G5-ML2 series
 - 12 to 24-VDC power supply input: 12 VDC-5% to 24 VDC+5%
 - Control input: ON level: 10 V or more, OFF level: 3 V or less (input current: 10 mA max.)

• Control output

The G5-ML2 series has three control outputs, less than the four control outputs of the G series by one.

Therefore, for the G5-ML2 series, narrow down the control outputs required for applications to two, except for *Servo alarm*.

G-ML2 series				G5-ML2 series			
Terminal	No.	Symbol	Name	Terminal	No.	Symbol	Name
CN1	15	/ALM	Alarm Output	CN1	3	/ALM	Alarm Output
	16	ALMCOM			4	ALMCOM	
	36	OUTM1	General-purpose Output 1*1		1	OUTM1	General-purpose Output 1*2
	35	OUTM1COM	(BKIR: Brake Interlock Output)		2	OUTM1COM	(BKIR: Brake Interlock Output)
	29	OUTM2	General-purpose Output 2*1		25	OUTM2	General-purpose Output 2*2
	30	OUTM2COM	(Not assigned: Always OFF)		26	OUTM2COM	(READY: Servo Ready Output)
	31	OUTM3	General-purpose Output 3*1		-	-	No corresponding output.
32	OUTM3COM	(Not assigned: Always OFF)	-	-			

*1. For the general-purpose outputs 1 to 3, output functions can be changed by using **General-purpose Output 1 Function Selection** (Pn112) to **General-purpose Output 3 Function Selection** (Pn114).

The setting in parentheses shows the default setting.

*2. For the general-purpose outputs 1 and 2, output functions can be changed by using **Output Signal Selection 1** (Pn410) and **2** (Pn411).

The setting in parentheses shows the default setting.

[Electrical specifications]

- In both the G-ML2 and the G5-ML2 series
 - Control output: Maximum service voltage: 30 VDC, Maximum output current: 50 mA

■ Encoder connector

The encoder connectors of the G-ML2 series and the G5-ML2 series are the same in wiring.

G-ML2 series				G5-ML2 series			
Terminal	No.	Symbol	Name	Terminal	No.	Symbol	Name
CN2	1	E5V	Encoder power supply +5 V	CN2	1	E5V	Encoder power supply +5 V
	2	E0V	Encoder power supply GND		2	E0V	Encoder power supply GND
	3	BAT+	Battery +		3	BAT+	Battery +
	4	BAT-	Battery -		4	BAT-	Battery -
	5	PS+	Encoder + phase S input		5	PS+	Encoder + phase S input
	6	PS-	Encoder - phase S input		6	PS-	Encoder - phase S input
	Shell	FG	Shield ground		Shell	FG	Frame ground

■ Communications-related connector

The G5-ML2 series does not support the RS-232 communications and Parameter Unit functions of the G-ML2 series.

For the G5-ML2 series, parameters can be set from CX-Drive (computer tool) via USB communications.

G-ML2 series				G5-ML2 series			
Terminal	No.	Symbol	Name	Terminal	No.	Symbol	Name
CN6A	-	-	MECHATROLINK-II communications connectors	ML2A	-	-	MECHATROLINK-II communications connectors
CN6B	-	-	MECHATROLINK-II communications connectors	ML2B	-	-	MECHATROLINK-II communications connectors
CN3	3	TXD	RS-232 send data	CN7	1	VBUS	USB signal terminal
	4	GND	Ground		2	D-	
	5	RXD	RS-232 receive data		3	D+	
					4	-	Do not connect.
					5	GND	Signal ground

■ Analog monitor output terminal and connector

Although the G-ML2 series uses check pins, the G5-ML2 series uses connectors instead.

G-ML2 series				G5-ML2 series			
Terminal	No.	Symbol	Name	Terminal	No.	Symbol	Name
CP	-	SP	Speed monitor check pin	CN5	1	AM1	Analog monitor output 1
	-	IM	Torque monitor check pin		2	AM2	Analog monitor output 2
	-	G	Check pin ground		3	GND	Analog monitor ground
			4		-	Do not connect.	
			5		-		
			6		-		

[Electrical specifications]

- G-ML2 series
 - Speed monitor check pin: Set by using **Speed monitor (SP) Selection** (Pn007).
 - Torque monitor check pin: Set by using **Torque Monitor (IM) Selection** (Pn008).
- G5-ML2 series:
 - Analog monitor output 1: Set by using **Analog Monitor 1 Selection** (Pn416) and **Analog Monitor 1 Scale Setting** (Pn417).
 - Analog monitor output 2: Set by using **Analog Monitor 2 Selection** (Pn418) and **Analog Monitor 2 Scale Setting** (Pn419).

■ Safety connector

The G5-ML2 series supports the Safe Torque OFF (STO) function of the safety standards.

At the time of replacement from the G-ML2 series, consider this function if you also wish to improve safety in the device.

G-ML2 series				G5-ML2 series			
Terminal	No.	Symbol	Name	Terminal	No.	Symbol	Name
				CN8	1	-	Do not connect.
					2	-	
					3	SF1-	Safety input 1
					4	SF1+	
					5	SF2-	Safety input 2
					6	SF2+	
					7	EDM-	EDM output
					8	EDM+	
				Shell	FG	Frame ground	

[Electrical specifications]

- G5-ML2 series
 - Safety Input External Power Supply: 12 VDC-5% to 24 VDC+5%
 - Safety input: ON level: 10 V or more, OFF level: 3 V or less
 - EDM output: Maximum service voltage: 30 VDC, Maximum output current: 50 mA

7. Gain Adjustment Methods

7.1. Gain Adjustment Method (Auto Tuning)

Using CX-Drive (computer tool) allows auto tuning of the G5-ML2 series to be executed. Auto tuning of the G5-ML2 series is described below, so execute auto tuning of the replaced device.

■ Starting *Auto Tune Wizard* of G5-ML2 series

Double-click Auto Tune from the tuning function in the workspace of CX-Drive (computer tool) to start the auto tuning wizard.

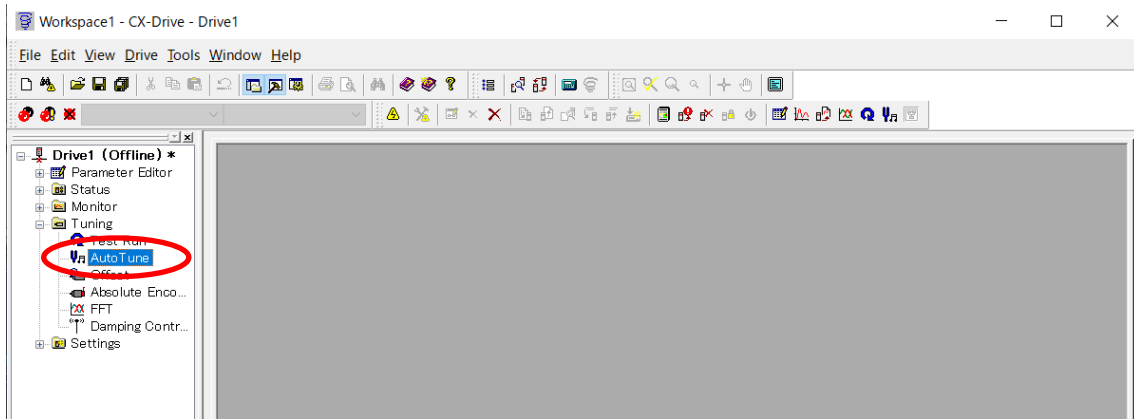

■ Selecting *1: Tuning Type* of G5-ML2 series

When the auto tuning wizard is started, *1: Tuning Type* is displayed, then select one of the three tuning modes. Choose *Automatic Auto Tune (Easy)*, and click *Next*.

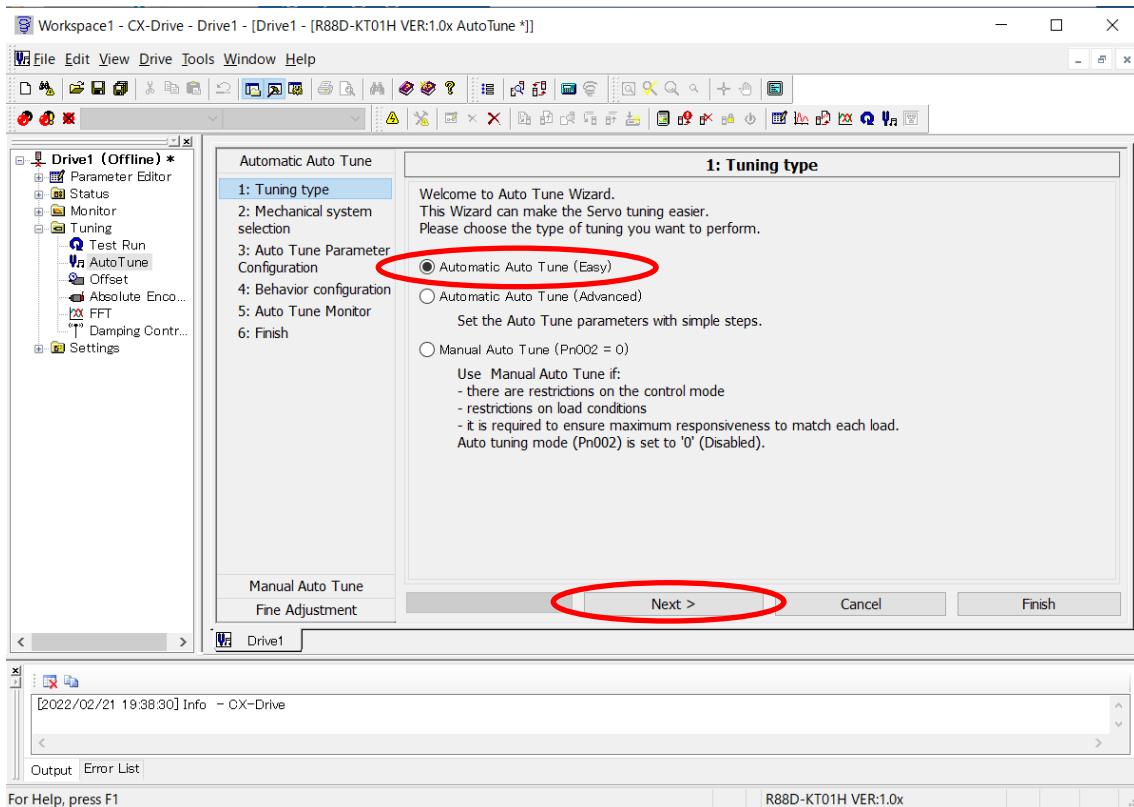

■ 2: Mechanical system selection of G5-ML2 series

Select a machine configuration of the motor to execute auto tuning for, and click Next.

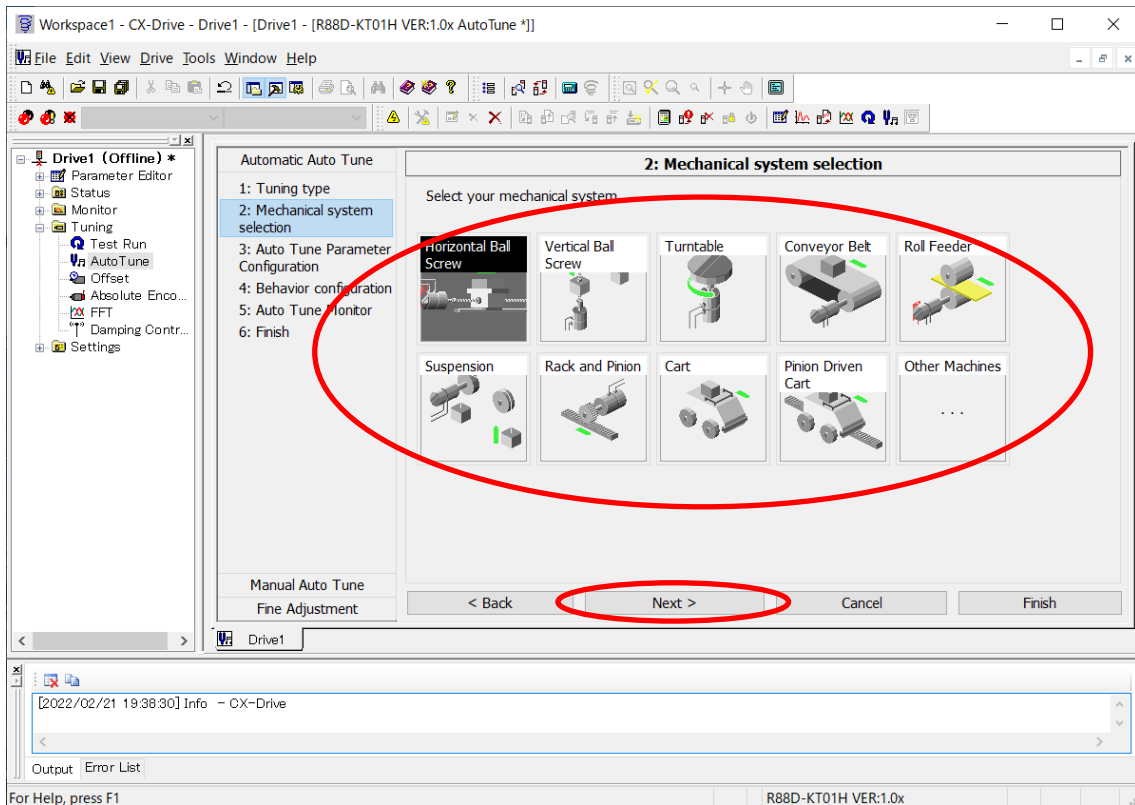

■ 3: Auto Tune Parameter Configuration of G5-ML2 series

Set the machine rigidity of the motor to execute auto tuning for.

When the coupling rigidity from the motor shaft to the load end is high and low, increase and decrease the value respectively. If you cannot judge that, set a default value of the selected machine configuration (12 in the following example), and click Next.

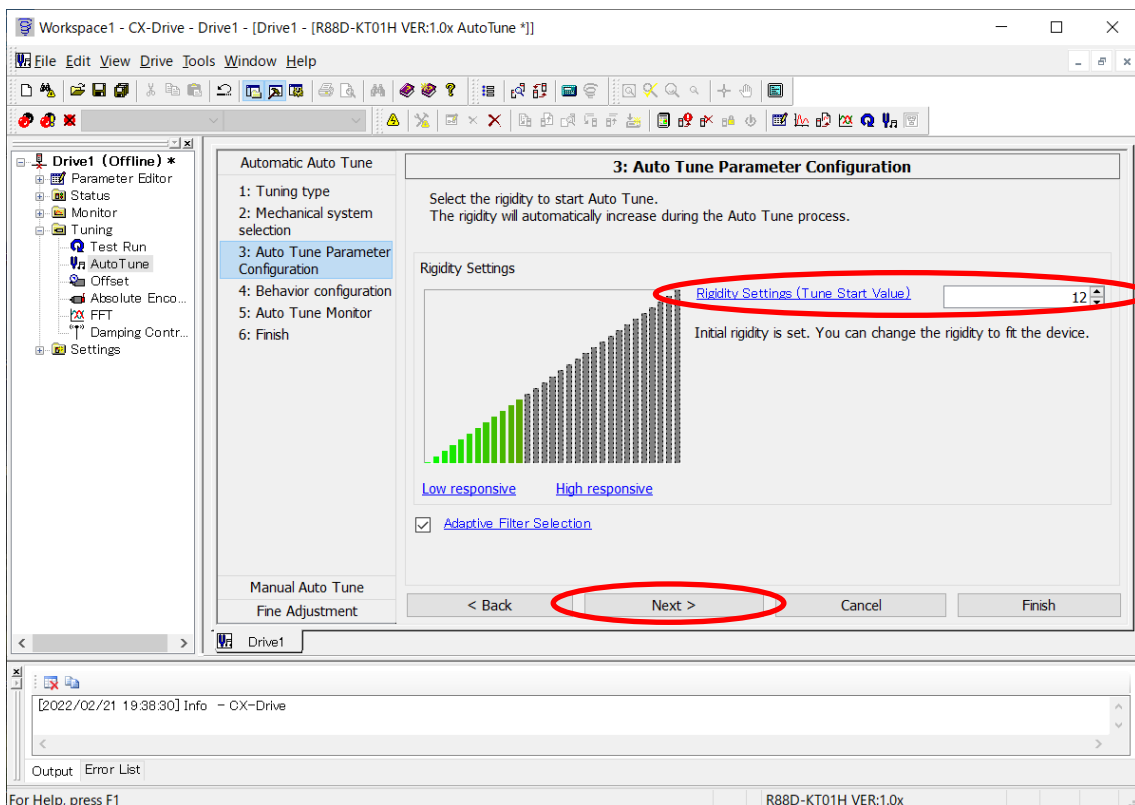

■ 4: Behavior configuration of G5-ML2 series

Fill in the Auto Tune Configuration, Motion Profile Generator, and Criteria for finishing Auto Tune fields of auto tuning, and click *Next*.

- Auto Tune Configuration
 - Set the number of times in Number of tuning iterations.
 - Set the time of one tuning in Duration of a tuning iteration.
 - * Start tuning with default values; if the tuning was inadequate, set enough number and time.
- Motion Profile Generator
 - Select one of the following two commands for operation to execute auto tuning.
 - The Motion Controller will perform the motion profile: Issues commands from the drive controlling controller to execute auto tuning.
 - CX-Drive (and not the motion controller) will perform the motion profile: The operation is commanded by CX-Drive.
 - * As the JOG commands of CX-Drive, set Operation (operation method), Step distance, Step Jog Speed, and Acceleration/Deceleration Time of the motor.
- Criteria for finishing Auto Tune
 - Set the positioning stabilization time when auto tuning is completed.
 - As the conditions for that motion, set *Overshoot level*, *Torque vibration level*, and *Positioning Completion Range 1*.
 - * Auto tuning may not be completed depending on the setting of *Stabilization time* or *Positioning Completion Range 1*. In that case, increase one of the settings, and execute it again.
 - * Auto tuning may not be completed if *Overshoot level* is set too low.
 - * Detecting a vibration of *Torque vibration level* results in a stop. In that case, increase the setting, and execute it again. Alternatively, enable adaptive filters, or read vibration frequencies from torque waveforms and set these frequencies to notch filters to reduce the gains of vibration generating frequencies, and then execute it again.

G5-ML2 series			Remarks
Parameter No. [dec]	Parameter name	Default setting [dec]	
Pn200	Adaptive Filter Selection	0	To enable adaptive filters, set 2: <u>Two adaptive filters enabled (3rd and 4th notch filters used).</u>
Pn201	Notch 1 Frequency Setting	5,000 Hz	To use notch filters, set vibrating frequencies to Notch 1 Frequency Setting/Notch 2 Frequency Setting (Pn201/Pn204).
Pn204	Notch 2 Frequency Setting		

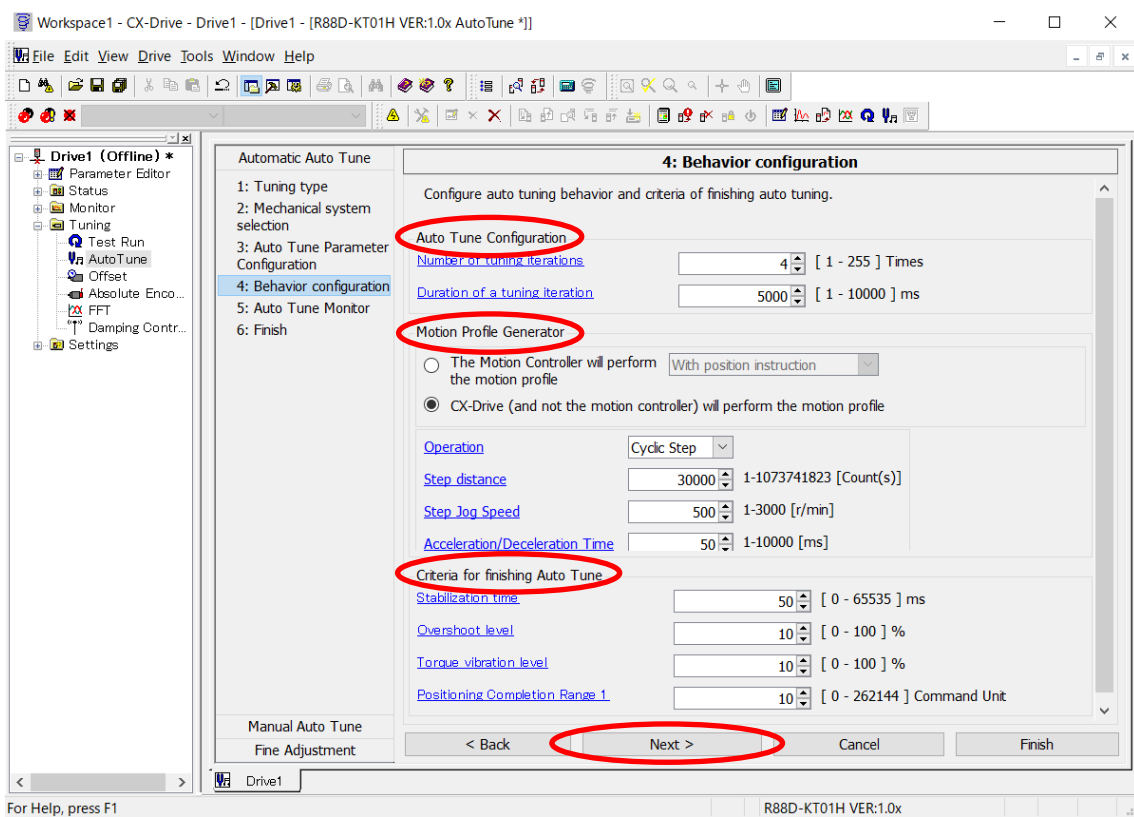

■ 5: Auto Tune Monitor of G5-ML2 series

Pressing the *Start* button starts auto tuning. To abort auto tuning, press the *Stop* button.

To check operation waveforms after auto tuning is completed, put a check mark in *View Auto Tune results with data trace*, and then start auto tuning.

When auto tuning is completed, click *Finish*.

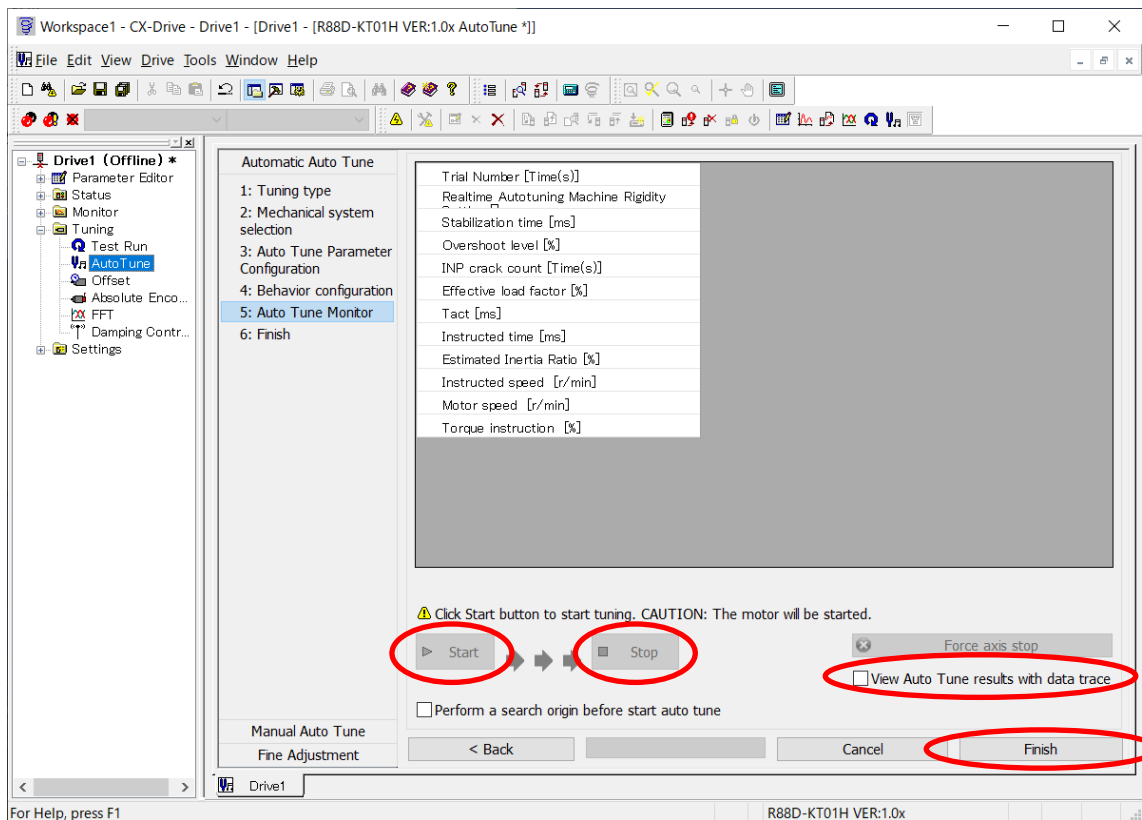

- * If you perform auto tuning with rapid acceleration/deceleration applied to operation commands, Error counter overflow (Alarm No. 24) may be detected. In that case, increase the set value of **Error Counter Overflow Level** (Pn014) temporarily, and execute auto tuning again. After auto tuning is finished, put the **Error Counter Overflow Level** (Pn014) setting back to the original set value, or set it to a proper value again.

G5-ML2 series			Remarks
Parameter No. [dec]	Parameter name	Default setting [dec]	
Pn014	Error Counter Overflow Level	100,000 Command unit	Set the detection level of Error counter overflow (Alarm No. 24). For the G5-ML2 series, the command unit (command pulse unit) is used in setting. * The setting unit of the G5-ML2 can be changed to 1: Encoder unit (external scale unit) by using Position Setting Unit Selection (Pn520).

6: Finish of G5-ML2 series

A list of parameter values set as the results of auto tuning is displayed. Check the tuning results of the parameters. For the G5-ML2 series, the auto tuning results of gain-related parameters are saved automatically to the non-volatile memory of the drive; however, click *Save to EEPROM* so as to save all the related parameters to the non-volatile memory. Clicking *Finish* will finish the auto tuning wizard.

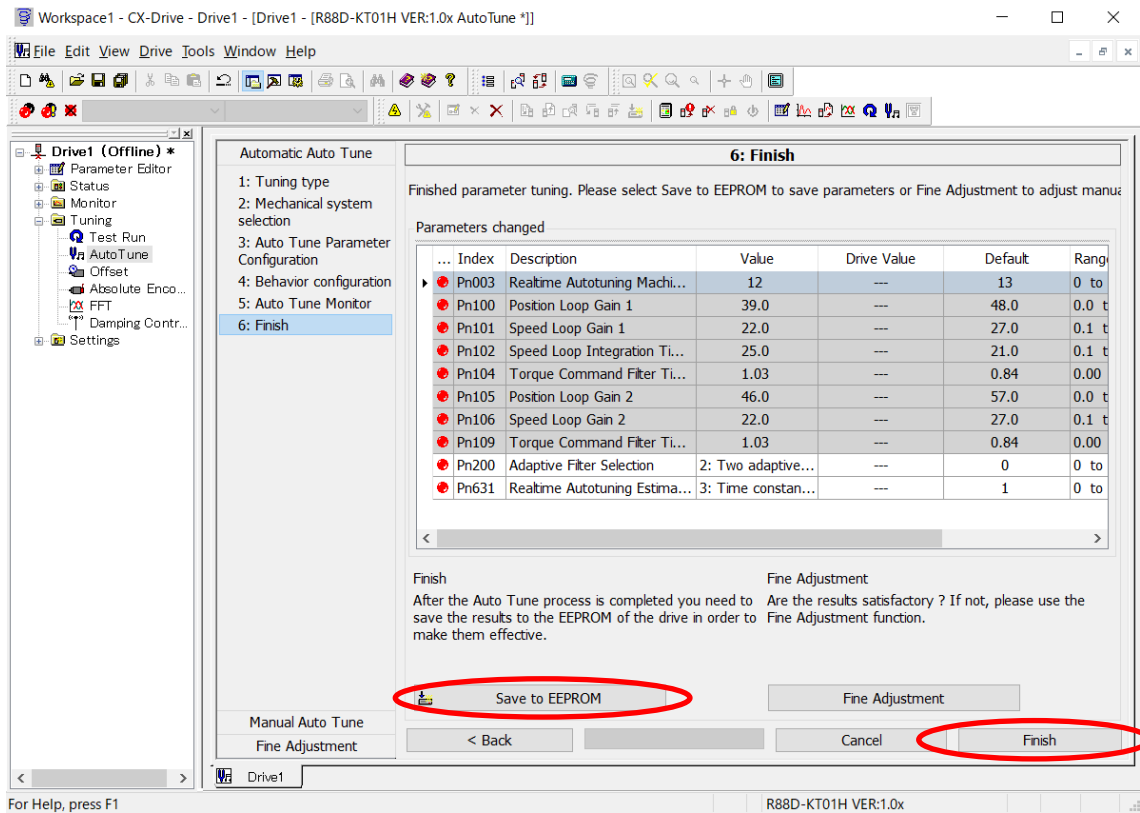

7.2. Using Gain Adjustment Values for G-ML2 Series as Those for G5-ML2 Series

It is possible to modify the gain adjustment values for G-ML2 series that had been used, so as to use them as those for G5-ML2 series.

The following table shows the four basic parameters related to gain adjustment.

According to *G-ML2 to G5-ML2 settings*, modify the gain adjustment values for G-ML2 series into those for G5-ML2 series.

* The G5-ML2 series has higher control performance, so it provides higher-speed and higher-precision operation as compared with the G-ML2 series.

If possible, you are recommended to use the auto tuning function to set them again, after replacement with the G5-ML2 series.

G-ML2 series			G5-ML2 series			G-ML2 to G5-ML2 settings
Parameter No. [hex]	Parameter name	Default setting [dec]	Parameter No. [dec]	Parameter name	Default setting [dec]	
Pn010	Position Loop Gain (RT)	40.0 s ⁻¹	Pn100	Position Loop Gain 1	48.0/32.0 s ⁻¹ *1	Set the proportional gain of position control. Set the value as it is, because the unit remains unchanged.
Pn011	Speed Loop Gain (RT)	50.0 Hz	Pn101	Speed Loop Gain 1	27.0/18.0 Hz*1	Set the proportional gain of speed control. Set the value as it is, because the unit remains unchanged.
Pn012	Speed Loop Integration Time Constant (RT)	20.0 ms	Pn102	Speed Loop Integral Time Constant 1	21.0/31.0 ms*1	Set the integration time constant of speed control. Set the value as it is, because the unit remains unchanged.
Pn014	Torque Command Filter Time Constant (RT)	0.80 ms	Pn104	Torque Command Filter Time Constant 1	0.84/1.26 ms*1	Set the torque command filter time constant of torque control. Set the value as it is, because the unit remains unchanged.

*1. For the numerical notation sv/SV, sv represents the setting for less than 1 kW drives of 100 V or 200 V type, and SV represents the setting for other drives.

8. Connecting with Host Controllers

The G-ML2 series is connected to the host controller of MECHATROLINK-II communications type, such as the MECHATROLINK-II-ready Position Control Unit CJ1W-NC□71.

When the G-ML2 series is replaced with the G5 series, there will be a difference in the encoder resolution of the motor; therefore, if it is made to operate in the G5 series after replacement, positioning may be carried out differently.

As shown below, use the electronic gear functions to correct the encoder resolution.

The following settings will remove the influence on the host controller side and allow you to use the settings and programs of the host controller without having to change them.

G-ML2 series			G5-ML2 series		
Parameter No. [hex]	Parameter name	Default setting [dec]	Parameter No. [dec]	Parameter name	Default setting [dec]
Pn205	Electronic Gear Ratio 1 (Numerator)	1	Pn009	Electronic Gear Ratio Numerator	1
Pn206	Electronic Gear Ratio 2 (Denominator)	1	Pn010	Electronic Gear Ratio Denominator	1

■ When electronic gear functions (Pn205/Pn206) of G-ML2 series are default settings

The default setting of the G-ML2 series is that the motor is rotated once by the command pulses of encoder resolution of the motor.

Therefore, set the values in which a difference in the encoder resolution of the motor is reflected.

The description is divided into two, because the resolution is different between the incremental encoder and the absolute (absolute value) encoder in both the G-ML2 and the G5-ML2 series.

(1) For the incremental encoder

Set the following values to the electronic gear functions (Pn009/Pn010) of the G5-ML2 series.

- **Electronic Gear Ratio Numerator** (Pn009) = 0

* If 0 is set to **Electronic Gear Ratio Numerator** (Pn009), the encoder resolution of the motor in use will be set automatically to the electronic gear numerator.

- **Electronic Gear Ratio Denominator** (Pn010) = 10,000

* Set the resolution 10,000 (multiple of 4) of the incremental encoder of the G-ML2 series.

(2) For the absolute (absolute value) encoder

The G-ML2 series and the G5-ML2 series are the same in absolute (absolute value) encoder resolution.

For the electronic gear functions (Pn009/Pn010), their default settings can be used as they are.

■ When Electronic Gear Ratio 1 (Numerator) (Pn205) of G-ML2 series is 0

Set the values that are set in **Electronic Gear Ratio 1 (Numerator)** (Pn205) and **Electronic Gear Ratio 2 (Denominator)** (Pn206) of G-ML2 series, respectively to **Electronic Gear Ratio Numerator** (Pn009) and **Electronic Gear Ratio Denominator** (Pn010) of G5-ML2.

- Electronic gear functions of G-ML2 and G5-ML2 series

In both the G-ML2 and the G5-ML2 series, if 0 is set to **Electronic Gear Ratio 1 (Numerator)/Electronic Gear Ratio Numerator** (Pn205/Pn009), the encoder resolution of the motor in use will be set automatically to the electronic gear numerator. Therefore, the motor is rotated once by the command pulse setting of **Electronic Gear Ratio 2 (Denominator)/Electronic Gear Ratio Denominator** (Pn206/Pn010).

■ When Electronic Gear Ratio 1 (Numerator) (Pn205) of G-ML2 series is ≠ 0

When **Electronic Gear Ratio 1 (Numerator)** (Pn205) of the G-ML2 series is ≠ 0, set the values in which a difference in the encoder resolution of the motor is reflected.

The description is divided into two, because the resolution is different between the incremental encoder and the absolute (absolute value) encoder in both the G-ML2 and the G5-ML2 series.

If the following calculation result has exceeded the parameter setting range, reduce fractions to a common denominator to convert the value into a smaller one before setting it.

(1) For the incremental encoder

Set the following values to the electronic gear functions (Pn009/Pn010) of the G5-ML2 series.

- **Electronic Gear Ratio Numerator** (Pn009) = **Electronic Gear Ratio 1 (Numerator)** (Pn205) of G-ML2 series x 1,048,576

- **Electronic Gear Ratio Denominator** (Pn010) = **Electronic Gear Ratio 2 (Denominator)** (Pn206) of G-ML2 series x 10,000

(2) For the absolute (absolute value) encoder

The G-ML2 series and the G5-ML2 series are the same in absolute (absolute value) encoder resolution.

Set the values that are set in **Electronic Gear Ratio 1 (Numerator)** (Pn205) and **Electronic Gear Ratio 2 (Denominator)** (Pn206) of G-ML2 series, respectively to **Electronic Gear Ratio Numerator** (Pn009) and **Electronic Gear Ratio Denominator** (Pn010) of G5-ML2.

9. Detailed Comparison of Parameters

9.1. Function Selection Parameters

G-ML2 series			G5-ML2 series			Remarks
Parameter No. [hex]	Parameter name	Default setting [dec]	Parameter No. [dec]	Parameter name	Default setting [dec]	
Pn000	Reserved	1	-	-	-	-
Pn001	Default Display	0	Pn700	Default Display	0	Set the data to be displayed on the 7-segment LED display. <ul style="list-style-type: none"> In both the G-ML2 and the G5-ML2, the default setting is 0: Indicates "--" during Servo-OFF, and "00" during Servo-ON.
Pn002	Reserved	0	-	-	-	-
Pn003	Torque Limit Selection	1	Pn521	Torque Limit Selection	1	Set the method to switch the torque limits to use, and the torque feed-forward function. <ul style="list-style-type: none"> The default setting of the G-ML2 is 1: The limit value for forward and reverse operation is No. 1 Torque Limit (Pn05E) setting, and the torque feed-forward function is enabled only in speed control. The default setting of the G5-ML2 is 1: The limit value for forward and reverse operation is No. 1 Torque Limit (Pn013) setting, and the torque feed-forward function is enabled only in speed control.
Pn004	Drive Prohibit Input Selection	0	Pn504	Drive Prohibition Input Selection	1	Set whether to enable or disable the drive prohibition function. <ul style="list-style-type: none"> The default setting of the G-ML2 is 0: Enabled, to decelerate and stop according to the setting of Stop Selection for Drive Prohibition Input (Pn066). The default setting of the G5-ML2 is 1: Disabled.
Pn005	Communications Control	0	Pn800	Communications Control	0	Enable or disable the alarms and warnings about MECHATROLINK-II communications. <ul style="list-style-type: none"> In both the G-ML2 and the G5-ML2, the default setting is 0: All the alarms and warnings are enabled.
Pn006	Power ON Address Display Duration Setting	30 ms	Pn701	Power ON Address Display Duration Setting	0 x 100 ms	Set the time during which the node address is displayed when the control power supply is turned ON. <ul style="list-style-type: none"> The default setting of the G-ML2 is 30 ms. The default setting of the G5-ML2 is 0 ms.
Pn007	Speed monitor (SP) Selection	3	Pn416	Analog Monitor 1 Selection	0	Set the monitor and scale to output to the analog speed monitor (SP) and the analog monitor 1 (AM1). <ul style="list-style-type: none"> In both the G-ML2 and the G5-ML2, the default setting is Motor speed (3,000 r/min.: 6 V). For the G-ML2, use Speed monitor (SP) Selection (Pn007) to set both a monitor and a scale. For the G5-ML2, use Analog Monitor 1 Selection (Pn416) to select a monitor, and use Analog Monitor 1 Scale Setting (Pn417) to set a scale.
			Pn417	Analog Monitor 1 Scale Setting	0	
Pn008	Torque Monitor (IM) Selection	0	Pn418	Analog Monitor 2 Selection	4	Set the monitor and scale to output to the analog torque monitor (IM) and the analog monitor 2 (AM2). <ul style="list-style-type: none"> In both the G-ML2 and the G5-ML2, the default setting is Torque command (100% of rated torque: 3 V). For the G-ML2, use Torque Monitor (IM) Selection (Pn008) to set both a monitor and a scale. For the G5-ML2, use Analog Monitor 2 Selection (Pn418) to select a monitor, and use Analog Monitor 2 Scale Setting (Pn419) to set a scale.
			Pn419	Analog Monitor 2 Scale Setting	0	

G-ML2 series			G5-ML2 series			Remarks
Parameter No. [hex]	Parameter name	Default setting [dec]	Parameter No. [dec]	Parameter name	Default setting [dec]	
Pn009	Reserved	0	-	-	-	-
Pn00A	Prohibit Parameter Changes via Network	0	-	-	-	Prohibit parameters from being changed via network. <ul style="list-style-type: none"> The default setting of the G-ML2 is 0: <i>Allows parameter changes.</i> * The G5-ML2 does not have the Prohibit Parameter Changes via Network parameter.
Pn00B	Operation Switch When Using Absolute Encoder	0	Pn015	Operation Switch when Using Absolute Encoder	1	Set the usage of the absolute encoder. <ul style="list-style-type: none"> The default setting of the G-ML2 is 0: <i>Use as an absolute encoder.</i> The default setting of the G5-ML2 is 1: <i>Use as incremental encoder.</i> * To use an absolute encoder, after connecting a battery for backups, connect the absolute encoder, and perform the Absolute Encoder Setup.
Pn00C	RS-232 Baud Rate Setting	2	-	-	-	Set the baud rate for RS-232 communications. <ul style="list-style-type: none"> The default setting of the G-ML2 is 2: <i>9,600 bps.</i> The G5-ML2 does not have the RS-232 communications function.
Pn00D	Reserved	0	-	-	-	-
Pn00E	Reserved	0	-	-	-	-
Pn00F	Reserved	0	-	-	-	-

9.2. Parameters Related to Gain

G-ML2 series			G5-ML2 series			Remarks
Parameter No. [hex]	Parameter name	Default setting [dec]	Parameter No. [dec]	Parameter name	Default setting [dec]	
Pn010	Position Loop Gain (RT)	40.0 s ⁻¹	Pn100	Position Loop Gain 1	48.0/32.0 s ^{-1*1}	Set the proportional gain of position control. • The default setting differs between G-ML2 and G5-ML2.
Pn011	Speed Loop Gain (RT)	50.0 Hz	Pn101	Speed Loop Gain 1	27.0/18.0 Hz*1	Set the proportional gain of speed control. • The default setting differs between G-ML2 and G5-ML2.
Pn012	Speed Loop Integration Time Constant (RT)	20.0 ms	Pn102	Speed Loop Integral Time Constant 1	21.0/31.0 ms*1	Set the integration time constant of speed control. • The default setting differs between G-ML2 and G5-ML2.
Pn013	Speed Feedback Filter Time Constant (RT)	0	Pn103	Speed Feedback Filter Time Constant 1	0	Set the filter time constant in the speed detection section. • In both the G-ML2 and the G5-ML2, the default setting is 0 (<i>high responsiveness</i>). • In both the G-ML2 and the G5-ML2, increasing the set value can suppress vibration but will reduce responsiveness.
Pn014	Torque Command Filter Time Constant (RT)	0.80 ms	Pn104	Torque Command Filter Time Constant 1	0.84/1.26 ms*1	Set the torque command filter time constant of torque control. • The default setting differs between G-ML2 and G5-ML2.
Pn015	Speed Feedforward Amount (RT)	30.0 %	Pn110	Speed Feed-forward Amount	30.0 %	Set the feed-forward amount to be transmitted from position control to speed control. • In both the G-ML2 and the G5-ML2, the default setting is 30%.
Pn016	Feed-forward Filter Time Constant (RT)	1.00 ms	Pn111	Speed Feed-forward Command Filter	0.50 ms	Set the filter time constant in the feed-forward section to be transmitted from position control to speed control. • The default setting differs between G-ML2 and G5-ML2.
Pn017	Reserved	0	-	-	-	-
Pn018	Position Loop Gain 2 (RT)	20.0 s ⁻¹	Pn105	Position Loop Gain 2	57.0/38.0 s ^{-1*1}	Set the proportional gain of position control. • The default setting differs between G-ML2 and G5-ML2.
Pn019	Speed Loop Gain 2 (RT)	80.0 Hz	Pn106	Speed Loop Gain 2	27.0/18.0 Hz*1	Set the proportional gain of speed control. • The default setting differs between G-ML2 and G5-ML2.
Pn01A	Speed Loop Integration Time Constant 2 (RT)	50.0 ms	Pn107	Speed Loop Integration Time Constant 2	1,000.0 ms	Set the integration time constant of speed control. • The default setting differs between G-ML2 and G5-ML2.
Pn01B	Speed Feedback Filter Time Constant 2 (RT)	0	Pn108	Speed Feedback Filter Time Constant 2	0	Set the filter time constant in the speed detection section. • In both the G-ML2 and the G5-ML2, the default setting is 0 (<i>high responsiveness</i>).
Pn01C	Torque Command Filter Time Constant 2 (RT)	1.00 ms	Pn109	Torque Command Filter Time Constant 2	0.84/1.26 ms*1	Set the torque command filter time constant of torque control. • The default setting differs between G-ML2 and G5-ML2.
Pn01D	Notch Filter 1 Frequency	1,500 Hz	Pn201	Notch 1 Frequency Setting	5,000 Hz	Set the frequency of the 1st resonance suppression notch filter. • For the default setting of the G-ML2, the notch function is disabled at 1,500 Hz. • For the default setting of the G5-ML2, the notch function is disabled at 5,000 Hz.
Pn01E	Notch Filter 1 Width	2	Pn202	Notch 1 Width Setting	2	Set the width of the 1st resonance suppression notch filter. • In both the G-ML2 and the G5-ML2, the default setting is 2. • In both the G-ML2 and the G5-ML2, increasing the set value will obtain a larger width. * For the G5-ML2, the notch filter depth can be set to Notch 1 Depth Setting (Pn203).
			Pn203	Notch 1 Depth Setting	0	
Pn01F	Reserved	0	-	-	-	-

*1. For the numerical notation sv/SV, sv represents the setting for less than 1 kW drives of 100 V or 200 V type, and SV represents the setting for other drives.

G-ML2 series			G5-ML2 series			Remarks
Parameter No. [hex]	Parameter name	Default setting [dec]	Parameter No. [dec]	Parameter name	Default setting [dec]	
Pn020	Inertia Ratio (RT)	300 %	Pn004	Inertia Ratio	250 %	Set the ratio of load inertia to the motor rotor inertia in units of %. <ul style="list-style-type: none"> For the G-ML2, it is automatically set when you execute normal mode auto tuning. Or, it is automatically updated when you enable Realtime Autotuning Mode Selection (Pn021). For the G5-ML2, it is automatically updated when you enable REALTIME AUTOTUNING mode Selection (Pn002).
Pn021	Realtime Autotuning Mode Selection	0	Pn002	REALTIME AUTOTUNING mode Selection	1	Set the functional operation that estimates the load condition in real time and corrects the control constant. <ul style="list-style-type: none"> The default setting of the G-ML2 is <i>0: Disabled</i>. The default setting of the G5-ML2 is <i>1: This mode focuses on stability</i>. * In replacement, set it to <i>0: Disabled</i> like the G-ML2.
Pn022	Realtime Autotuning Machine Rigidity Selection	2	Pn003	Realtime Autotuning Machine Rigidity Setting	13/11 *1	Set the rigidity of equipment for real-time auto tuning. <ul style="list-style-type: none"> The default setting differs between G-ML2 and G5-ML2. Adjust the setting according to the rigidity of equipment.
Pn023	Adaptive Filter Selection	0	Pn200	Adaptive Filter Selection	0	Set the operation of adaptive filters. <ul style="list-style-type: none"> In both the G-ML2 and the G5-ML2, the default setting is <i>0: Adaptive filter disabled</i>.
Pn024	Vibration Filter Selection	0	Pn213	Damping Filter Selection	0	Set the operation of damping filters. <ul style="list-style-type: none"> In both the G-ML2 and the G5-ML2, the default setting is <i>0: Damping filters 1 and 2 can be used</i>.
Pn025	Normal Mode Autotuning Operation Setting	0	-	-	-	Set the operation pattern of normal mode auto tuning. <ul style="list-style-type: none"> The G5-ML2 does not have the related parameter. * For the G5-ML2, execute the auto tuning with the operation pattern set, from CX-Drive (computer tool).
Pn026	Overrun Limit Setting	1.0 Rotation	Pn514	Overrun Limit Setting	1.0 Rotation	Set the allowable operating range for the position command input range. Going beyond the range causes an Overrun Limit Error (Alarm No. 34) to be detected. <ul style="list-style-type: none"> In both the G-ML2 and the G5-ML2, the default setting is <i>1.0 rotation</i>.
Pn027	Instantaneous Speed Observer Setting (RT)	0	Pn610	Function Expansion Setting	0	Set the operation of the instantaneous speed observer. <ul style="list-style-type: none"> In both the G-ML2 and the G5-ML2, the default setting is <i>Disabled</i>. * For the G5-ML2, one parameter sets the following four functions. Enable or disable the functions by means of their respective bits. <ul style="list-style-type: none"> bit 0: Instantaneous speed observer function bit 1: Disturbance observer function bit 2: Disturbance observer operation setting bit 3: Not used (always 0). bit 4: Electric current response improvement function bit 5: Not used (always 0).
Pn028	Notch Filter 2 Frequency	1,500 Hz	Pn204	Notch 2 Frequency Setting	5,000 Hz	Set the frequency of the 2nd resonance suppression notch filter. <ul style="list-style-type: none"> For the default setting of the G-ML2, the notch function is disabled at <i>1,500 Hz</i>. For the default setting of the G5-ML2, the notch function is disabled at <i>5,000 Hz</i>.

*1. For the numerical notation sv/SV, sv represents the setting for less than 1 kW drives of 100 V or 200 V type, and SV represents the setting for other drives.

G-ML2 series			G5-ML2 series			Remarks
Parameter No. [hex]	Parameter name	Default setting [dec]	Parameter No. [dec]	Parameter name	Default setting [dec]	
Pn029	Notch Filter 2 Width	2	Pn205	Notch 2 Width Setting	2	Set the width of the 2nd resonance suppression notch filter. <ul style="list-style-type: none"> In both the G-ML2 and the G5-ML2, the default setting is 2. In both the G-ML2 and the G5-ML2, increasing the set value will obtain a larger width.
Pn02A	Notch Filter 2 Depth	0	Pn206	Notch 2 Depth Setting	0	Set the depth of the 2nd resonance suppression notch filter. <ul style="list-style-type: none"> In both the G-ML2 and the G5-ML2, the default setting is 0. In both the G-ML2 and the G5-ML2, increasing the set value will obtain a shallower depth.
Pn02B	Vibration Frequency 1	0.0 Hz	Pn213	Damping Filter Selection	0	Damping control is a function that suppresses vibration at the load end. Set the damping frequency of the damping filter 1. <ul style="list-style-type: none"> In both the G-ML2 and the G5-ML2, the default setting is 0.0 Hz and the damping filter is disabled. * Setting 0.0 to 0.9 Hz disables the damping filter. For the G-ML2, the damping filters 1 and 2 can always be used. For the G5-ML2, the default setting of Damping Filter Selection (Pn213) is 0: <i>Damping filter 1 or 2 enabled.</i> * For the G5-ML2, in the setting of Damping Filter Selection (Pn213), four damping filters can be changed by rotation directions and external inputs (DFSEL1 and DFSEL2).
			Pn214	Damping Frequency 1	0.0 Hz	
Pn02C	Vibration Filter 1 Setting	0.0 Hz	Pn215	Damping Filter 1 Setting	0.0 Hz	Set the vibration suppression effect of the 1st damping filter. <ul style="list-style-type: none"> In both the G-ML2 and the G5-ML2, the default setting is 0.0 Hz. In both the G-ML2 and the G5-ML2, increasing the value will hasten the operation of vibration suppression. Decrease the value if torque saturation occurs to prevent vibration suppression.
Pn02D	Vibration Frequency 2	0.0 Hz	Pn216	Damping Frequency 2	0.0 Hz	Set the damping frequency of the damping filter 2. <ul style="list-style-type: none"> In both the G-ML2 and the G5-ML2, the default setting is 0.0 Hz and the damping filter is disabled. * Setting 0.0 to 0.9 Hz disables the damping filter.
Pn02E	Vibration Filter 2 Setting	0.0 Hz	Pn217	Damping Filter 2 Setting	0.0 Hz	Set the vibration suppression effect of the 2nd damping filter. <ul style="list-style-type: none"> In both the G-ML2 and the G5-ML2, the default setting is 0.0 Hz.
Pn02F	Adaptive Filter Table Number Display	0	Pn207	Notch 3 Frequency Setting	5,000 Hz	This is a monitor that checks the operating status of adaptive filters. <ul style="list-style-type: none"> For the G-ML2, you can check the operating frequencies of adaptive filters. For the G5-ML2, the operating status of adaptive filters is updated automatically to the parameters of Notch 3/4 Frequency Setting (Pn207/Pn210).
			Pn210	Notch 4 Frequency Setting	5,000 Hz	
Pn030	Gain Switching Operating Mode Selection (RT)	1	Pn114	GAIN SWITCHING INPUT OPERATING mode Selection	1	Set the function of gain switching input (GSEL). <ul style="list-style-type: none"> The default setting of the G-ML2 is 1: <i>The gain is switched between Gain 1 (Pn010 to Pn014) and Gain 2 (Pn018 to Pn01C).</i> The default setting of the G5-ML2 is 1: <i>Gain 1 (Pn100 to Pn104)/gain 2 (Pn105 to Pn109) switching available.</i> * When 0: <i>Gain 1 (PI/P switching enabled)</i> is set, speed control can be switched to proportional (P) control to reduce the gain.

G-ML2 series			G5-ML2 series			Remarks
Parameter No. [hex]	Parameter name	Default setting [dec]	Parameter No. [dec]	Parameter name	Default setting [dec]	
Pn031	Gain Switch Setting (RT)	2	Pn115	SWITCHING mode in Position Control	0	<p>Select a condition for switching between Gain 1 and Gain 2.</p> <ul style="list-style-type: none"> The default setting of the G-ML2 is <u>2: By switching from the network, the gain is switched between Gain 1 (Pn010 to Pn014) and Gain 2 (Pn018 to Pn01C).</u> For the G5-ML2, position control, speed control, and torque control can be configured differently. <ul style="list-style-type: none"> The default setting of SWITCHING mode in Position Control (Pn115) is <i>0: Always Gain 1 (Pn100 to Pn104).</i> The default setting of SWITCHING mode in Speed Control (Pn120) is <i>0: Always the Gain 1 (Pn100 to Pn104).</i> The default setting of SWITCHING mode in Torque Control (Pn124) is <i>0: Always Gain 1 (Pn100 to Pn104).</i> * If <u>2: By switching from the network, the gain is switched between Gain 1 (Pn100 to Pn104) and Gain 2 (Pn105 to Pn109)</u> is set to Pn115/Pn120/Pn124 of the G5, it will operate the same as the G-ML2.
			Pn120	SWITCHING mode in Speed Control	0	
			Pn124	SWITCHING mode in Torque Control	0	
Pn032	Gain Switch Time (RT)	30 x 166 us	Pn116	Gain Switching Delay Time in Position Control	5.0 ms	<p>Set the delay time for returning from Gain 2 to Gain 1.</p> <ul style="list-style-type: none"> The default setting of the G-ML2 is <i>30 x 166 us (4,980 us).</i> For the G5-ML2, position control, speed control, and torque control can be configured differently. <ul style="list-style-type: none"> The default setting of Gain Switching Delay Time in Position Control (Pn116) is <i>5.0 ms.</i> The default setting of Gain Switching Delay Time in Speed Control (Pn121) is <i>0.0 ms.</i> The default setting of Gain Switching Delay Time in Torque Control (Pn125) is <i>0.0 ms.</i>
			Pn121	Gain Switching Delay Time in Speed Control	0.0 ms	
			Pn125	Gain Switching Delay Time in Torque Control	0.0 ms	
Pn033	Gain Switch Level Setting (RT)	600	Pn117	Gain Switching Level in Position Control	50	<p>Set the judgment level for switching between Gain 1 and Gain 2.</p> <ul style="list-style-type: none"> The default setting of the G-ML2 is <i>600.</i> * The unit varies with the set value of Gain Switch Setting (RT) (Pn031). For the G5-ML2, position control, speed control, and torque control can be configured differently. <ul style="list-style-type: none"> The default setting of Gain Switching Level in Position Control (Pn117) is <i>50.</i> * The unit varies with the set value of SWITCHING mode in Position Control (Pn115). The default setting of Gain Switching Level in Speed Control (Pn122) is <i>0.</i> * The unit varies with the set value of SWITCHING mode in Speed Control (Pn120). The default setting of Gain Switching Level in Torque Control (Pn126) is <i>0.</i> * The unit varies with the set value of SWITCHING mode in Torque Control (Pn124).
			Pn122	Gain Switching Level in Speed Control	0	
			Pn126	Gain Switching Level in Torque Control	0	

G-ML2 series			G5-ML2 series			Remarks
Parameter No. [hex]	Parameter name	Default setting [dec]	Parameter No. [dec]	Parameter name	Default setting [dec]	
Pn034	Gain Switch Hysteresis Setting (RT)	50	Pn118	Gain Switching Hysteresis in Position Control	33	<p>Set a hysteresis to the judgment level for switching between Gain 1 and Gain 2.</p> <ul style="list-style-type: none"> The default setting of the G-ML2 is 50. * The unit varies with the set value of Control Gain Switch 1 Setting (Pn031). For the G5-ML2, position control, speed control, and torque control can be configured differently. <ul style="list-style-type: none"> The default setting of Gain Switching Hysteresis in Position Control (Pn118) is 33. * The unit varies with the set value of SWITCHING mode in Position Control (Pn115). The default setting of Gain Switching Hysteresis in Speed Control (Pn123) is 0. * The unit varies with the set value of SWITCHING mode in Speed Control (Pn120). The default setting of Gain Switching Hysteresis in Torque Control (Pn127) is 0. * The unit varies with the set value of SWITCHING mode in Torque Control (Pn124).
			Pn123	Gain Switching Hysteresis in Speed Control	0	
			Pn127	Gain Switching Hysteresis in Torque Control	0	
Pn035	Position Loop Gain Switching Time (RT)	20 x 166 us	Pn119	Position Gain Switching Time	3.3 ms	<p>In switching between Gain 1 and Gain 2, the phased switching time can be set for position loop gain only.</p> <ul style="list-style-type: none"> The default setting of the G-ML2 is 20 x 166 us (3,320 us). The default setting of the G5-ML2 is 3.3 ms.
Pn036	Reserved	0	-	-	-	-
Pn037	Reserved	0	-	-	-	-
Pn038	Reserved	0	-	-	-	-
Pn039	Reserved	0	-	-	-	-
Pn03A	Reserved	0	-	-	-	-
Pn03B	Reserved	0	-	-	-	-
Pn03C	Reserved	0	-	-	-	-
Pn03D	Jog Speed	200 r/min	-	-	-	<p>Set the jog speed at which jog operation is performed from the controls on the front of the Serve Drive.</p> <ul style="list-style-type: none"> The default setting of the G-ML2 is 200 r/min. The G5-ML2 does not have the related parameter. * For the G5-ML2, set the speed from CX-Drive (computer tool) to perform jog operation.
Pn03E	Reserved	0	-	-	-	-
Pn03F	Reserved	0	-	-	-	-

9.3. Parameters Related to Position Control

G-ML2 series			G5-ML2 series			Remarks
Parameter No. [hex]	Parameter name	Default setting [dec]	Parameter No. [dec]	Parameter name	Default setting [dec]	
Pn040	Reserved	0	-	-	-	-
Pn041	Emergency Stop Input Setting	1	Pn400	Input Signal Selection 1	00949494 hex	<p>Set whether to enable or disable the immediate stop input.</p> <ul style="list-style-type: none"> The default setting of the G-ML2 is <u>1: Enabled (STOP: CN1-2 pin)</u>. For the G5-ML2, assign a necessary function to an input terminal. The default setting of Input Signal Selection 1 (Pn400) is <u>00949494 hex: For position control, speed control, or torque control: Immediate stop input (STOP: CN1-5 pin) that is an NC contact.</u> * To disable the emergency stop input in the G5-ML2, set another function, or set <u>00000000 hex: For position control, speed control, or torque control: Disabled.</u>
Pn042	Origin Proximity Input Logic Setting	1	Pn403	Input Signal Selection 4	00222222 hex	<p>Set the logic for the origin proximity input.</p> <ul style="list-style-type: none"> The default setting of the G-ML2 is <u>1: NO contact (normally open, origin proximity detected on CLOSE) (DEC: CN1-21 pin)</u>. For the G5-ML2, assign a necessary function to an input terminal. The default setting of Input Signal Selection 4 (Pn403) is <u>00222222 hex: For position control, speed control, or torque control: Origin proximity input (STOP: CN1-9 pin) that is an NO contact.</u> * To change the logic in the G5-ML2, set <u>00A2A2A2 hex: For position control, speed control, or torque control: Origin proximity input (STOP: CN1-9 pin) that is an NC contact.</u>
Pn043	Operating Direction Setting	1	Pn000	Rotation Direction Switching	1	<p>Set the motor rotation direction for the direction of position commands, speed commands, or torque commands.</p> <ul style="list-style-type: none"> In both the G-ML2 and the G5-ML2, the default setting is <u>1: A forward direction command (+) sets the CCW direction (forward direction) seen from axis direction.</u>
Pn044	Input Signal Selection	0	Pn401	Input Signal Selection 2	00818181 hex	<p>Change the assignment of forward drive prohibition (POT: CN1-19 pin) and reverse drive prohibition (NOT: CN1-20 pin).</p> <ul style="list-style-type: none"> The default setting of the G-ML2 is <u>0: Forward drive prohibition (POT) to CN1-19 pin, Reverse drive prohibition (NOT) to CN1-20 pin.</u> For the G5-ML2, assign a necessary function to an input terminal. The default setting of Input Signal Selection 2 (Pn401) is <u>00818181 hex: For position control, speed control, or torque control: Forward drive prohibition (POT: CN1-7 pin) that is an NC contact.</u> The default setting of Input Signal Selection 3 (Pn402) is <u>00828282 hex: For position control, speed control, or torque control: Reverse drive prohibition (NOT: CN1-8 pin) that is an NC contact.</u> * For the G5-ML2, the assignment can be changed by reversing the two parameter settings.
			Pn402	Input Signal Selection 3	00828282 hex	
Pn045	Reserved	0	-	-	-	-
Pn046	Reserved	0	-	-	-	-
Pn047	Reserved	0	-	-	-	-
Pn048	Reserved	0	-	-	-	-
Pn049	Reserved	0	-	-	-	-
Pn04A	Reserved	0	-	-	-	-
Pn04B	Reserved	0	-	-	-	-
Pn04C	Reserved	0	-	-	-	-

G-ML2 series			G5-ML2 series			Remarks
Parameter No. [hex]	Parameter name	Default setting [dec]	Parameter No. [dec]	Parameter name	Default setting [dec]	
Pn04D	Reserved	0	-	-	-	-
Pn04E	Reserved	0	-	-	-	-
Pn04F	Reserved	0	-	-	-	-

9.4. Parameters Related to Speed and Torque Control

G-ML2 series			G5-ML2 series			Remarks
Parameter No. [hex]	Parameter name	Default setting [dec]	Parameter No. [dec]	Parameter name	Default setting [dec]	
Pn050	Reserved	0	-	-	-	-
Pn051	Reserved	0	-	-	-	-
Pn052	Reserved	0	-	-	-	-
Pn053	Speed Limit	50 r/min	Pn321	Speed Limit Value Setting	50 r/min	Set a speed limit value for torque control. <ul style="list-style-type: none"> In both the G-ML2 and the G5-ML2, the default setting is <i>50 r/min</i>.
Pn054	Reserved	0	-	-	-	-
Pn055	Reserved	0	-	-	-	-
Pn056	Reserved	0	-	-	-	-
Pn057	Reserved	0	-	-	-	-
Pn058	Soft Start Acceleration Time	0 x 2 ms/ Maximum motor speed	Pn312	Soft Start Acceleration Time	0 ms/ Maximum motor speed	Set the acceleration/deceleration time to the speed command inside the Servo Drive. <ul style="list-style-type: none"> In both the G-ML2 and the G5-ML2, the default setting is <i>0 ms</i>. In both the G-ML2 and the G5-ML2, set the acceleration/deceleration time of up to maximum motor speed. Be careful in setting because the setting unit is different. * In both the G-ML2 and the G5-ML2, for position control, set <i>0 ms</i> to the soft start acceleration/deceleration time.
Pn059	Soft Start Deceleration Time	0 x 2 ms/ Maximum motor speed	Pn313	Soft Start Deceleration Time	0 ms/ Maximum motor speed	
Pn05A	Reserved	0	-	-	-	-
Pn05B	Speed Limit Selection	0	Pn317	Speed Limit Selection	0	Set how to limit speed for torque control. <ul style="list-style-type: none"> The default setting of the G-ML2 is <i>0: Use the Speed Limit (Pn053)</i>. The default setting of the G5-ML2 is <i>0: Use the Speed Limit Value Setting (Pn321)</i>.
Pn05C	Reserved	0	-	-	-	-
Pn05D	Reserved	0	-	-	-	-
Pn05E	No. 1 Torque Limit	300 %	Pn013	No. 1 Torque Limit	500 %	Set the limit value of torque limits in units of %, with the rated motor torque regarded as 100%. <ul style="list-style-type: none"> The default setting differs between G-ML2 and G5-ML2. For the G-ML2, you can use the setting of Torque Limit Selection (Pn003) to set how to limit torque. <ul style="list-style-type: none"> The default selection of Torque Limit Selection (Pn003) is <u>1: No. 1 Torque Limit (Pn05E)</u> for both forward and reverse operation. For the G5-ML2, you can use the setting of Torque Limit Selection (Pn521) to set how to limit torque. <ul style="list-style-type: none"> The default selection of Torque Limit Selection (Pn521) is <u>1: No. 1 Torque Limit (Pn013)</u> for both forward and reverse operation.
Pn05F	No. 2 Torque Limit	100 %	Pn522	No. 2 Torque Limit	500 %	

9.5. Parameters Related to Sequence

G-ML2 series			G5-ML2 series			Remarks
Parameter No. [hex]	Parameter name	Default setting [dec]	Parameter No. [dec]	Parameter name	Default setting [dec]	
Pn060	Positioning Completion Range 1	25 Command unit	Pn431	Positioning Completion Range 1	10 Command unit	<p>Set the positioning completion range of the positioning completion output 1 (INP1).</p> <ul style="list-style-type: none"> In both the G-ML2 and the G5-ML2, the command unit (command pulse unit) is used in setting. The output condition of the G-ML2 is fixed at <u>Output when there is no position command (all positioning command pulses are exhausted) and the position error reaches not more than Positioning Completion Range 1 (Pn060).</u> For the G5-ML2, use Positioning Completion Condition Selection (Pn432) to set the output condition. <ul style="list-style-type: none"> The default setting of Positioning Completion Condition Selection (Pn432) is 0: <u>Output when the position error is within the Positioning Completion Range 1 (Pn431).</u> If 1: <u>Output when there is no position command (all positioning command pulses are exhausted) and the position error reaches not more than Positioning Completion Range 1 (Pn431)</u> is set, it will operate the same as the G-ML2. Be careful in setting because the motor resolution is different between the G-ML2 and the G5-ML2. The setting unit of the G5-ML2 can be changed to 1: <i>Encoder unit (external scale unit)</i> by using Position Setting Unit Selection (Pn520).
			Pn432	Positioning Completion Condition Selection	0	
			Pn520	Position Setting Unit Selection	0	
Pn061	Speed Conformity Signal Output Width	20 r/min	Pn435	Speed Conformity Detection Range	50 r/min	<p>Set the detection range of the speed conformity detection (VCMP).</p> <p>It is output when the difference between speed command and motor speed reaches less than the set detection range.</p> <ul style="list-style-type: none"> The default setting differs between G-ML2 and G5-ML2.
Pn062	Rotation Speed for Motor Rotation Detection	50 r/min	Pn436	Rotation Speed for Motor Rotation Detection	1000 r/min	<p>Set the rotation speed at which to output the motor rotation speed detection (TGON).</p> <ul style="list-style-type: none"> The default setting differs between G-ML2 and G5-ML2.
Pn063	Positioning Completion Range 2	100 Command unit	Pn442	Positioning Completion Range 2	10 Command unit	<p>Set the positioning completion range of the positioning completion output 2 (INP2).</p> <ul style="list-style-type: none"> In both the G-ML2 and the G5-ML2, the command unit (command pulse unit) is used in setting. The output condition of the G-ML2 is fixed at <u>Output when the position error reaches not more than Positioning Completion Range 2 (Pn063).</u> The output condition of the G5-ML2 is fixed at <u>Output when the position error reaches not more than Positioning Completion Range 2 (Pn442).</u> Be careful in setting because the motor resolution is different between the G-ML2 and the G5-ML2. The setting unit of the G5-ML2 can be changed to 1: <i>Encoder unit (external scale unit)</i> by using Position Setting Unit Selection (Pn520).
			Pn520	Position Setting Unit Selection	0	
Pn064	Motor Phase Current Offset Re-adjustment Setting	0	-	-	-	<p>Set whether to readjust the offset of the Motor Phase Current Detector (CT) when the servo is ON.</p> <ul style="list-style-type: none"> The default setting of the G-ML2 is 0: <i>Disabled.</i> The G5-ML2 does not have the related parameter.

G-ML2 series			G5-ML2 series			Remarks
Parameter No. [hex]	Parameter name	Default setting [dec]	Parameter No. [dec]	Parameter name	Default setting [dec]	
Pn065	Undervoltage Alarm Selection	1	Pn508	Undervoltage Alarm Selection	1	Set whether to enable or disable a Main power supply undervoltage (Alarm No. 13). <ul style="list-style-type: none"> In both the G-ML2 and the G5-ML2, the default setting is <u>1: During Servo ON status, a main power supply undervoltage (Alarm No. 13) is detected.</u>
Pn066	Stop Selection for Drive Prohibition Input	0	Pn505	Stop Selection for Drive Prohibition Input	0	Set the stop method when the drive prohibition function is activated by the input of Forward/Reverse drive prohibition input (POT/NOT). <ul style="list-style-type: none"> In both the G-ML2 and the G5-ML2, the default setting is <u>0: After a dynamic brake stop (error counter cleared), the torque command is 0 in the drive prohibition direction (error counter held).</u>
Pn067	Stop Selection with Main Power Supply OFF	0	Pn507	Stop Selection with Main Power Supply OFF	0	Set the stop method for main power supply OFF. <ul style="list-style-type: none"> In both the G-ML2 and the G5-ML2 series, the default setting is <u>0: After a dynamic brake stop, the dynamic brake is held.</u> * However, if any alarm (error) is detected during a stop, it will be overridden by Stop Selection for Alarm Generation/Stop Selection for Alarm Detection (Pn068/Pn510).
Pn068	Stop Selection for Alarm Generation	0	Pn510	Stop Selection for Alarm Detection	0	Set the stop method for alarm (error) occurrence. <ul style="list-style-type: none"> In both the G-ML2 and the G5-ML2 series, the default setting is <u>0: After a dynamic brake stop, the dynamic brake is held.</u>
Pn069	Stop Selection with Servo OFF	0	Pn506	Stop Selection with Servo OFF	0	Set the stop method for servo OFF. <ul style="list-style-type: none"> In both the G-ML2 and the G5-ML2 series, the default setting is <u>0: After a dynamic brake stop, the dynamic brake is held.</u>
Pn06A	Brake Timing When Stopped	10 x 2 ms	Pn437	Brake Timing when Stopped	0 ms	Set the servo ON hold time, at servo OFF, after the brake interlock output turned OFF. <ul style="list-style-type: none"> The default setting differs between G-ML2 and G5-ML2.
Pn06B	Brake Timing during Operation	50 x 2 ms	Pn438	Brake Timing during Operation	0 ms	Set the time spent waiting for the brake that reduces rotation to be applied when the Servo OFF is applied to the running motor. <ul style="list-style-type: none"> The default setting of the G-ML2 is <u>50 x 2 ms (100 ms).</u> * For the G-ML2, when the speed reaches 30 r/min or less, the brake will be applied even if the wait time set in Brake Timing during Operation (Pn06B) has not elapsed. The default setting of the G5-ML2 is <u>0 ms.</u> * For the G5-ML2, when the motor speed reaches not more than the speed set in Brake Release Speed Setting (Pn439), the brake will be applied even if the wait time set in Brake Timing during Operation (Pn438) has not elapsed.
			Pn439	Brake Release Speed Setting	30 r/min	
Pn06C	Regeneration Resistor Selection	0	Pn016	Regeneration Resistor Selection	3/0*2	Set the regeneration processing method. <ul style="list-style-type: none"> The default setting of the G-ML2 is <u>0: Built-in regeneration resistor.</u> * Even if the Servo Drive does not have a built-in regeneration resistor, this is acceptable to operation. The default setting of the G5-ML2 is <u>3: Built-in capacitor.</u> * The default setting of the Servo Drive with a built-in regeneration resistor is <u>0: Built-in regeneration resistor.</u>

*2. For the numerical notation sv/SV, sv represents the setting for the following drives. SV represents the setting for other drives.

- 100 V type: 200 W or less
- 200 V type: 400 W or less

G-ML2 series			G5-ML2 series			Remarks
Parameter No. [hex]	Parameter name	Default setting [dec]	Parameter No. [dec]	Parameter name	Default setting [dec]	
Pn06D	Momentary Hold Time	35 x 2 ms	Pn509	Momentary Hold Time	70 ms	Set the time spent waiting for a Main power supply undervoltage (Alarm No. 13) to be detected after the main power supply is shut off. <ul style="list-style-type: none"> In both the G-ML2 and the G5-ML2, the default setting is 70 ms. Be careful in setting because the setting unit is different.
Pn06E	Emergency Stop Torque	0 %	Pn511	Emergency Stop Torque	0 %	Set the stop torque to be used when you select an emergency stop method at Stop Selection for Drive Prohibition Input (Pn066/Pn505), Stop Selection with Main Power Supply OFF (Pn067/Pn507), or Stop Selection with Servo OFF (Pn069/Pn506). <ul style="list-style-type: none"> In both the G-ML2 and the G5-ML2, the default setting is 0%. * In both the G-ML2 and the G5-ML2, when you set 0%, the set torque limit value will be used.
Pn06F	Reserved	0	-	-	-	-
Pn070	Reserved	0	-	-	-	-
Pn071	Reserved	0	-	-	-	-
Pn072	Overload Detection Level Setting	0 %	Pn512	Overload Detection Level Setting	0 %	Set the detection level of an Overload (Alarm No. 16). <ul style="list-style-type: none"> In both the G-ML2 and the G5-ML2, the default setting is 0%. * In both the G-ML2 and the G5-ML2, when you set 0%, the Overload (Alarm No. 16) will be detected at 115%.
Pn073	Overspeed Detection Level Setting	0 r/min	Pn513	Overspeed Detection Level Setting	0 r/min	Set the detection level of an Overspeed error (Alarm No. 26). <ul style="list-style-type: none"> In both the G-ML2 and the G5-ML2, the default setting is 0 r/min. * In both the G-ML2 and the G5-ML2, if you set 0 r/min, it will be detected when the motor speed is 1.2 times as high as the maximum one.
Pn074 to Pn07F	Reserved	0	-	-	-	-

9.6. 16-bit Positioning Parameters: Parameter Nos. 100 to 13F

G-ML2 series			G5-ML2 series			Remarks
Parameter No. [hex]	Parameter name	Default setting [dec]	Parameter No. [dec]	Parameter name	Default setting [dec]	
Pn100	Backlash Compensation Selection	0	Pn704	Backlash Compensation Selection	0	Enable or disable the backlash compensation function, and set the compensation direction. <ul style="list-style-type: none"> In both the G-ML2 and the G5-ML2, the default setting is 0: Disabled.
Pn101	Backlash Compensation	0 Command unit	Pn705	Backlash Compensation Amount	0 Command unit	Set the compensation amount of the backlash compensation function. <ul style="list-style-type: none"> In both the G-ML2 and the G5-ML2, the default setting is 0 Command unit.
Pn102	Backlash Compensation Time Constant	0.00 ms	Pn706	Backlash Compensation Time Constant	0.00 ms	Set the time constant of the backlash compensation function. <ul style="list-style-type: none"> In both the G-ML2 and the G5-ML2, the default setting is 0.00 ms.
Pn103	Reserved	0	-	-	-	-
Pn104	Soft Limit	0	Pn801	Soft Limit	0	Set whether to enable or disable the software position limit function. <ul style="list-style-type: none"> In both the G-ML2 and the G5-ML2, the default setting is 0: Disabled.
Pn105	Origin Range	10 Command unit	Pn803	Origin Range	10 Command unit	Set the range of detecting the origin. The origin is detected when the feedback position is within \pm set value. <ul style="list-style-type: none"> In both the G-ML2 and the G5-ML2, the default setting is 10 Command unit.
Pn106	Reserved	0	-	-	-	-
Pn107	Linear Acceleration Constant	100 x 10,000 Command unit/s ²	Pn811	Linear Acceleration Constant	100 x 10,000 Command unit/s ²	Set the acceleration for positioning. <ul style="list-style-type: none"> In both the G-ML2 and the G5-ML2, the default setting is 100 x 10,000 Command unit/s². * In both the G-ML2 and the G5-ML2, when you set 0 x 10,000 Command unit/s², they will operate as if 1 x 10,000 Command unit/s² were set.
Pn108	Reserved	0	-	-	-	-
Pn109	Reserved	0	-	-	-	-
Pn10A	Linear Deceleration Constant	100 x 10,000 Command unit/s ²	Pn814	Linear Deceleration Constant	100 x 10,000 Command unit/s ²	Set the deceleration for positioning. <ul style="list-style-type: none"> In both the G-ML2 and the G5-ML2, the default setting is 100 x 10,000 Command unit/s². * In both the G-ML2 and the G5-ML2, when you set 0 x 10,000 Command unit/s², they will operate as if 1 x 10,000 Command unit/s² were set.
Pn10B	Reserved	0	-	-	-	-
Pn10C	Reserved	0	-	-	-	-
Pn10D	Reserved	0	-	-	-	-
Pn10E	Moving Average Time	0.0 ms	Pn222	Position Command Filter Time Constant	0.0 ms	Set the moving average time for the position command. <ul style="list-style-type: none"> The default setting of the G-ML2 is 0.0 ms. The G5-ML2 has the following two functions as the same functions. <ul style="list-style-type: none"> The default setting of Position Command Filter Time Constant (Pn222) is 0.0 ms. The default setting of Position Command FIR Filter Time Constant (Pn818) is 0.0 ms.
			Pn818	Position Command FIR Filter Time Constant	0.0 ms	
Pn10F	Origin Return Mode Settings	0	Pn822	Origin Return Mode Settings	0	Set the direction for origin return. <ul style="list-style-type: none"> In both the G-ML2 and the G5-ML2, the default setting is 0: Positive direction.
Pn110	Origin Return Approach Speed 1	50 x 100 Command unit/s	Pn823	Origin Return Approach Speed 1	50 x 100 Command unit/s	Set the speed for origin returns, from after the origin proximity is recognized to when the latch signal is detected. <ul style="list-style-type: none"> In both the G-ML2 and the G5-ML2, the default setting is 50 x 100 Command unit/s.
Pn111	Origin Return Approach Speed 2	5 x 100 Command unit/s	Pn824	Origin Return Approach Speed 2	5 x 100 Command unit/s	Set the speed for origin returns, from after the latch signal is detected to when the motor travels the Final Distance for Origin Return (Pn204/Pn825). <ul style="list-style-type: none"> In both the G-ML2 and the G5-ML2, the default setting is 5 x 100 Command unit/s.

G-ML2 series			G5-ML2 series			Remarks
Parameter No. [hex]	Parameter name	Default setting [dec]	Parameter No. [dec]	Parameter name	Default setting [dec]	
Pn112	General-purpose Output 1 Function Selection	7	Pn410	Output Signal Selection 1	00030303 hex	Set a function to output from the general-purpose output 1. <ul style="list-style-type: none"> The default setting of the G-ML2 is <u>7: Brake interlock output (BKIR)</u>. The default setting of the G5-ML2 is <u>00030303 hex: For position control, speed control, or torque control: Brake interlock output (BKIR) that is an NO contact.</u>
Pn113	General-purpose Output 2 Function Selection	0	Pn411	Output Signal Selection 2	00020202 hex	Set a function to output from the general-purpose output 2. <ul style="list-style-type: none"> The default setting of the G-ML2 is <u>0: Always OFF</u>. The default setting of the G5-ML2 is <u>00020202 hex: For position control, speed control, or torque control: Servo ready completed output (READY) that is an NO contact.</u>
Pn114	General-purpose Output 3 Function Selection	0	-	-	-	Set a function to output from the general-purpose output 3. <ul style="list-style-type: none"> The default setting of the G-ML2 is <u>0: Always OFF</u>. The G5-ML2 does not have a general-purpose output 3.
Pn115 to Pn13F	Reserved	0	-	-	-	-

9.7. 32-bit Positioning Parameters: Parameter Nos. 200 to 21F

G-ML2 series			G5-ML2 series			Remarks
Parameter No. [hex]	Parameter name	Default setting [dec]	Parameter No. [dec]	Parameter name	Default setting [dec]	
Pn200	Absolute Origin Offset	0 Command unit	Pn808	Absolute Encoder Origin Offset	0 Command unit	Set the offset value between the encoder position and mechanical coordinate position when the absolute encoder is used. <ul style="list-style-type: none"> In both the G-ML2 and the G5-ML2, the default setting is <i>0 Command unit</i>.
Pn201	Forward Software Limit	5×10^5 Command unit	Pn804	Forward Software Limit	5×10^5 Command unit	Set the forward software limit. <ul style="list-style-type: none"> In both the G-ML2 and the G5-ML2, the default setting is 5×10^5 <i>Command unit</i>.
Pn202	Reverse Software Limit	-5×10^5 Command unit	Pn806	Reverse Software Limit	-5×10^5 Command unit	Set the reverse software limit. <ul style="list-style-type: none"> In both the G-ML2 and the G5-ML2, the default setting is -5×10^5 <i>Command unit</i>.
Pn203	Final Distance for External Input Positioning	100 Command unit	Pn820	Final Distance for External Input Positioning	100 Command unit	Set the distance to travel after the latch signal input position is detected during the external input positioning. <ul style="list-style-type: none"> In both the G-ML2 and the G5-ML2, the default setting is <i>100 Command unit</i>.
Pn204	Origin Return Final Distance	100 Command unit	Pn825	Final Distance for Origin Return	100 Command unit	Set the distance from the latch signal input position to the origin during origin returns. <ul style="list-style-type: none"> In both the G-ML2 and the G5-ML2, the default setting is <i>100 Command unit</i>.
Pn205	Electronic Gear Ratio 1 (Numerator)	1	Pn009	Electronic Gear Ratio Numerator	1	Set the electronic gear function. <ul style="list-style-type: none"> The default setting of the G-ML2 is <u>Electronic Gear Ratio 1 (Numerator) (Pn205) = 1, Electronic Gear Ratio 2 (Denominator) (P206) = 1</u>. For the incremental encoder, the motor is rotated once by 10,000 pulses. For the absolute encoder, the motor is rotated once by 131,072 pulses. The default setting of the G5-ML2 is <u>Electronic Gear Ratio Numerator (Pn009) = 1, Electronic Gear Ratio Denominator (Pn010) = 1</u>. For the incremental encoder, the motor is rotated once by 1048,576 pulses. For the absolute encoder, the motor is rotated once by 131,072 pulses. <p>* In both the G-ML2 and the G5-ML2, if 0 is set to the electronic gear ratio numerator, the resolution of the motor in use will be set automatically to the electronic gear numerator.</p>
Pn206	Electronic Gear Ratio 2 (Denominator)	1	Pn010	Electronic Gear Ratio Denominator	1	
Pn207	Reserved	0	-	-	-	-
Pn208	Reserved	0	-	-	-	-
Pn209	Deviation Counter Overflow Level	20,000 Command unit	Pn014	Error Counter Overflow Level	100,000 Command unit	Set the detection level of an Error Counter Overflow Error (Alarm No. 24). <ul style="list-style-type: none"> In both the G-ML2 and the G5-ML2, the command unit (command pulse unit) is used in setting. * In both the G-ML2 and the G5-ML2, when you set 0 to the error counter overflow level, the Error Counter Overflow Error (Alarm No. 24) will be disabled. * The setting unit of the G5-ML2 can be changed to 1: <i>Encoder unit (external scale unit)</i> by using Position Setting Unit Selection (Pn520).
Pn520	Position Setting Unit Selection				0	
Pn20A to Pn21F	Reserved	-	-	-	-	-

Appendix. Cables Connecting G5-ML2-series Servo Drives and Servomotors

Rated rotation speed	Main circuit power supply voltage	Motor capacity	Motor model R88M-	Power cable without brake R88A-		Power cable with brake R88A-		Encoder cable R88A-					
				Standard	Flexible	Standard	Flexible	Standard	Flexible				
3,000 r/min	100 V	50 W	K05030H/T□	CAKA△S	CAKA△SR	CAKA△S, CAKA△B	CAKA△SR, CAKA△BR	CRKA△C *3	CRKA△CR *3				
		100 W	K10030L/S□										
		200 W	K20030L/S□										
		400 W	K40030L/S□										
	200 V	50 W	K05030H/T□	CAKA△S	CAKA△SR	CAKA△S, CAKA△B	CAKA△SR, CAKA△BR						
		100 W	K10030H/T□										
		200 W	K20030H/T□										
		400 W	K40030H/T□										
		750 W	K75030H/T□	CAGB△S	CAGB△SR	CAGB△B	CAGB△BR						
		1 kW	K1K030H/T□										
		1.5 kW	K1K530H/T□										
		2 kW	K2K030H/T□										
	400 V	3 kW	K3K030H/T□	CAGD△S	CAGD△SR	CAGD△B	CAGD△BR						
		4 kW	K4K030H/T□										
		5 kW	K5K030H/T□										
		750 W	K75030F/C□							CAGB△S	CAGB△SR	CAKF△B	CAKF△BR
1 kW		K1K030F/C□											
1.5 kW		K1K530F/C□											
2 kW		K2K030F/C□											
3 kW		K3K030F/C□	CAGD△S	CAGD△SR	CAGD△B	CAGD△BR							
4 kW	K4K030F/C□												
5 kW	K5K030F/C□												
4 kW	K4K030F/C□												
2,000 r/min	200 V	1 kW	K1K020H/T□	CAGB△S	CAGB△SR	CAGB△B	CAGB△BR	CRKC△N *3	CRKC△NR *3				
		1.5 kW	K1K520H/T□										
		2 kW	K2K020H/T□										
		3 kW	K3K020H/T□										
		4 kW	K4K020H/T□										
	5 kW	K5K020H/T□	CAGD△S	CAGD△SR	CAGD△B	CAGD△BR							
	400 W	K40020F/C□											
	600 W	K60020F/C□											
	1 kW	K1K020F/C□											
	1.5 kW	K1K520F/C□											
	2 kW	K2K020F/C□											
	3 kW	K3K020F/C□											
4 kW	K4K020F/C□												
5 kW	K5K020F/C□												
1,500 r/min	200 V	(7.5 kW)	(K7K515T□)*2	CAGE△S	*4	CAGE△S, CAGE△B	*4	CRKC△N *3	CRKC△NR *3				
	400 V	(7.5 kW)	(K7K515C□)										
1,000 r/min	200 V	900 W	K90010H/T□	CAGB△S	CAGB△SR	CAGB△B	CAGB△BR	CRKC△N *3	CRKC△NR *3				
		2 kW	K2K010H/T□										
		3 kW	K3K010H/T□										
		(4.5 kW)	(K4K510T□)*2										
	400 V	(6 kW)	(K6K010T□)*2	CAGE△S	*4	CAGE△S, CAGE△B	*4						
		900 W	K90010F/C□							CAGB△S	CAGB△SR	CAKF△B	CAKF△BR
		2 kW	K2K010F/C□										
		3 kW	K3K010F/C□										
		(4.5 kW)	(K4K510C□)*2										
		(6 kW)	(K6K010C□)*2										

*1. □ represents an optional specification for the motor. △ represents a 3-digit cable length (005 for 5 m).
 *2. The G5 series with built-in MECHATROLINK-II communications has no model to be replaced with, so the motor for the G5 series with built-in EtherCAT communications is used instead.
 *3. When you use an absolute (absolute value) encoder, use the battery cable for absolute encoder (R88A-CRGD0R3C) in addition.
 *4. We have no plan to commercialize flexible-type power cables for 6 kW and 7.5 kW motors. They must be prepared by the customer.

Note: Do not use this document to operate the Unit.

OMRON Corporation Industrial Automation Company

Kyoto, JAPAN

Contact : www.ia.omron.com

Regional Headquarters

OMRON EUROPE B.V.

Wegalaan 67-69, 2132 JD Hoofddorp
The Netherlands
Tel: (31) 2356-81-300 Fax: (31) 2356-81-388

OMRON ELECTRONICS LLC

2895 Greenspoint Parkway, Suite 200
Hoffman Estates, IL 60169 U.S.A.
Tel: (1) 847-843-7900 Fax: (1) 847-843-7787

OMRON ASIA PACIFIC PTE. LTD.

438B Alexandra Road, #08-01/02 Alexandra
Technopark, Singapore 119968
Tel: (65) 6835-3011 Fax: (65) 6835-3011

OMRON (CHINA) CO., LTD.

Room 2211, Bank of China Tower,
200 Yin Cheng Zhong Road,
PuDong New Area, Shanghai, 200120, China
Tel: (86) 21-6023-0333 Fax: (86) 21-5037-2388

Authorized Distributor:

©OMRON Corporation 2022-2024 All Rights Reserved.
In the interest of product improvement,
specifications are subject to change without notice.

Cat. No. I878-E1-02 0124 (0422)